

# Assembly and Maintenance instructions LTD/CDC

Bearing assembly with torque-motor type LTD / CDC



## Table of Contents

<b>1</b>	<b>General</b> .....	<b>4</b>
<b>2</b>	<b>Layout and function</b> .....	<b>4</b>
<b>3</b>	<b>Security</b> .....	<b>4</b>
	3.1 Intended Use.....	4
	3.2 Sources of danger .....	5
	3.3 Protective measures .....	6
	3.4 Qualification of the staff.....	7
<b>4</b>	<b>Assembly of the bearing assembly</b> .....	<b>7</b>
<b>5</b>	<b>Commissioning torque-motor</b> .....	<b>7</b>
<b>6</b>	<b>Electrical connections</b> .....	<b>8</b>
	6.1 Pin assignment motor.....	8
	6.2 Pin assignment measuring system.....	9
	6.3 Temperature sensors .....	9
<b>7</b>	<b>Notes on operation</b> .....	<b>11</b>
<b>8</b>	<b>Eccentric loads</b> .....	<b>11</b>
<b>9</b>	<b>Maintenance</b> .....	<b>12</b>
	9.1 Maintenance safety notice .....	12
	9.2 Cleaning .....	13
	9.3 Relubrication.....	13
	9.4 Retighten screw connections.....	15
	9.5 Screw tightening torques.....	15
	9.6 Maintenance engine .....	15
<b>10</b>	<b>Declaration for the installation of a partly completed machine</b> .....	<b>16</b>
	10.1 Appendix to the declaration for the installation of a partly completed machine.....	17
<b>11</b>	<b>Attachment</b> .....	<b>18</b>

### Information about these instructions

These instructions enable the safe and efficient handling of the bearing assembly with integrated torque-motor. The instructions are part of the bearing assembly and must be kept in the immediate vicinity of the machine in which the bearing assembly is installed, accessible to the staff at all times.

The personnel must have carefully read and understood these instructions before starting any work. The basic requirement for safe working is compliance with all of the safety instructions and handling instructions in this manual.

In addition, the local occupational health and safety regulations and general safety regulations for the area of application of the bearing assembly apply.

### Customer service

Franke GmbH  
Obere Bahnstraße 64  
73431 Aalen, **Germany**  
Phone: +49 7361 920-0  
Fax: +49 7361 920-120  
Email: [info@franke-gmbh.de](mailto:info@franke-gmbh.de)  
Internet: [www.franke-gmbh.de](http://www.franke-gmbh.de)

Franke Bearings Ltd.  
Unit 5/90 Berry Lane  
PR3 3WH Longridge, **Great Britain**  
Phone: +44 177 2780200  
E-Mail: [sales@frankebearings.co.uk](mailto:sales@frankebearings.co.uk)  
Internet: [www.frankebearings.co.uk](http://www.frankebearings.co.uk)

### Copyright

The contents of these instructions are protected by copyright. Their use is permitted within the framework of the use of the bearing assembly. Any further use is not permitted without the written consent of Franke GmbH.

## 1 General

This document is part of the product and contains important information on installation, operation and maintenance. It is intended for people who carry out assembly, installation, commissioning and maintenance work on this product. These instructions must be made available to everyone in a legible condition.

## 2 Layout and function

The bearing assembly with integrated torque-motor is a drive unit that is used in the handling area, transfer lines, rotary indexing tables and in general automation.

The bearing assembly with torque-motor consists of:

- Stator in which the winding of the torque motor (3-phase synchronous motor) is integrated
- Rotor, which is equipped with permanent magnets
- possibly measuring system that records the actual position of the rotor

The dimensions and technical data of the respective version (LTD100, LTD215, LTD320 or LTD385) can be found in the appendix or on our homepage at [www.franke-gmbh.de](http://www.franke-gmbh.de) or, in the case of a customer-specific version, the drawing provided.

## 3 Security

### 3.1 Intended Use

The bearing assembly with integrated torque-motor is intended exclusively for commercial applications. These may only be used in an industrial environment.

The bearing assembly with torque-motor of the type LTD / CDC is an „incomplete machine“ within the meaning of the EC Machinery Directive 2006/42 / EC. Commissioning may only take place if it has been ensured beforehand that the machine in which it is installed complies with the statutory provisions regarding personal safety (in particular the EC Machinery Directive 2006/42 / EC) and the machine with the EMC Directive 2014 / 30 / EU complies.

### 3.2 Sources of danger



**DANGER**

Carry out all work on the bearing assembly only when the machine is switched off and make sure that there is no voltage applied to the torque motor.



**WARNING**

Sharp edges can cause cuts. Wear work gloves!



**DANGER**

The surface temperature of the bearing assembly can be hot. If work is carried out on the bearing assembly immediately after operation, there is a risk of burns.  
-> Let the motor cool down for at least 30 minutes.



**DANGER**

Strong permanent magnets are built into the rotor of the bearing assembly. Due to the high attraction forces, objects made of iron and steel must not be carried in close proximity. There is a risk of crushing!



**DANGER**

If the distance is too short, the magnetic field of the permanent magnet (<500 mm) disturb or destroy sensitive devices. This applies in particular to implanted electromedical devices (such as cardiac pacemakers), but also to watches and measuring devices, magnetic cards and electronic data carriers.



The user must point out these dangers in such a way that they can still be perceived from a safe distance (e.g. by means of warning signs). Access to the place of use by persons wearing implanted electro-medical devices must be prohibited.







**The user must ensure that interference or access by persons is impossible during operation.**

## 3.3 Protective measures





In the immediate vicinity of the danger points, the bearing assembly with torque-motor must be clearly marked with warning and prohibition signs.

The following tables show the signs to be attached and their meanings.

### Warning signs

Sign	Meaning
	Warning of dangerous electrical voltage (D-W008)
	Magnetic field warning (D-W013)
	Warning of hot surface (D-W026)
	Warning of hand injuries (D-W027)

### Prohibition signs

Sign	Meaning
	Carrying of magnetic or electronic data carriers is prohibited (D-P021)
	Ban on pacemakers (D-P011)
	Prohibition for people with implants made of metal (D-P016)
	It is forbidden to bring metal parts or watches (D-P020)

### 3.4 Qualification of the staff

Only trained specialists (e.g. industrial mechanics, locksmiths, mechatronics) are allowed to assemble and maintain bearing assemblies with torque-motors.

Only trained electricians (e.g. electricians, mechatronics engineers) are allowed to electrically connect and operate bearing assemblies with torque-motors.

## 4 Assembly of the bearing assembly with torque-motor

Do not assemble any damaged components.

- Place the rotary joint on the fastening surface and screw the fastening screws into the threaded holes.
- Check the ease of movement of the screws and the position of the holes.
- Screw the bearing assembly to the adjacent construction crosswise and tighten the screws with a torque wrench to the specified torque. (see chapter 9.5)

## 5 Commissioning torque-motor

- The torque motors must not be connected directly to the mains, only in conjunction with a suitable servo controller. The requirements for the servo controller can be found in the attached motor data sheets or the product-specific drawing.
- To protect the motor from overheating, please activate all existing protection systems:
  - Temperature sensors (usually PTC and PT1000) on the active motor phases in accordance with the IEC60034-11 standard
  - Limitation of the I<sub>2</sub> value, which determines the passage of current to the motor

## 6 Electrical connections

### ⚠ WARNING

**WARNING!**  
Unexpected start-up can cause serious injuries cause.

Switch off the energy supply before working on the bearing assembly with torque-motor. All mechanical assembly work must be completed before connection. Trial operation when not installed is prohibited. Only qualified electricians may connect the device.

### 6.1 Pin assignment motor

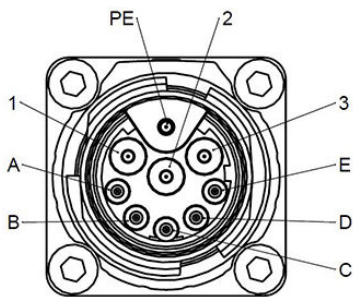

Fig. 01: Pin assignment motor

#### LTD100

Pin assignment motor  
Socket 917; M17x1 (9-pin)

#### Pin assignment

PIN	Signal	PIN	Signal
1	Phase U	A	PT1000
2	Phase V	B	PT1000
3	Phase W	C	PTC 120°
PE	protective conductor	D	PTC 120°
		E	free

#### LTD215, LTD320, LTD385

Pin assignment motor  
Angled socket 923, M23x1 (8-pin)

#### Pin assignment

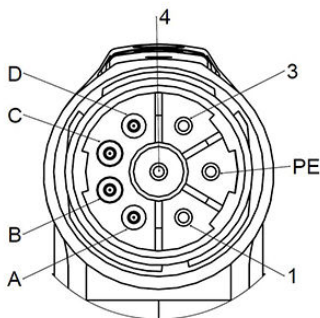

Fig. 02: Pin assignment motor

PIN	Signal	PIN	Signal
1	Phase U	A	PT1000
PE	PE	B	PT1000
3	Phase V	C	PTC 120°
4	Phase W	D	PTC 120°

LTD / CDC customer specific according to drawing



### 6.2 Pin assignment measuring system

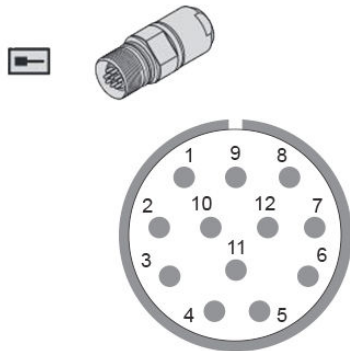

Fig. 03: Pin assignment measuring system

LTD100, LTD215, LTD320, LTD385

Pin assignment measuring system

03S12 12-pin coupling M23

#### Pin assignment

Power supply		Incremental signals		Other signals	
12	Up	5	A+	/	free
2	Sensor Up	6	A-	7	Diag+
10	0 V	8	B+	9	Diag-
11	Sensor 0 V	1	B-		
		3	R+		
		4	R-		

LTD / CDC customer-specific according to drawing (if available)

### 6.3 Temperature sensors

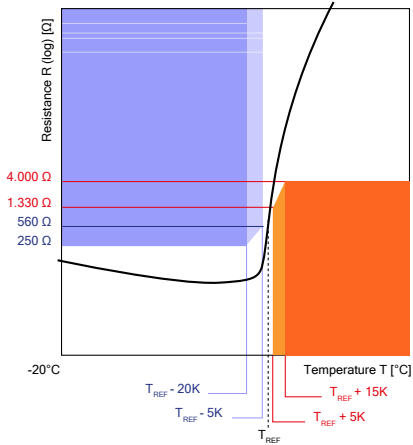

R, T, parameters for other TREF nominal response temperature) on request

Fig. 04: PTC

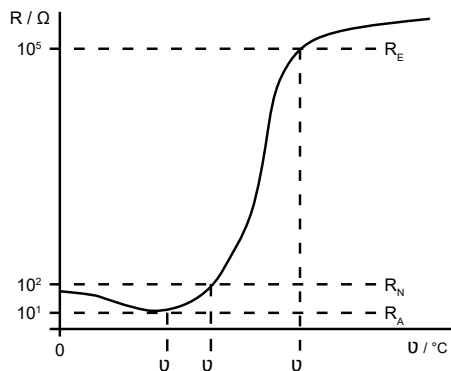

Fig. 05: PTC resistor

#### PTC

PTC thermistor

PTC thermistors are semiconductor resistors that are temperature-dependent. PTC thermistors have a positive temperature coefficient (TK) and are therefore also called PTC resistors (PTC = Positive Temperature Coefficient).

The diagram describes the resistance curve as a function of the temperature of a PTC resistor. The resistance value begins to rise at the initial temperature  $U_A$ . The resistance rises non-linearly up to the nominal temperature  $U_N$ . The resistance increases sharply from the nominal resistance  $R_N$ . The working range of the PTC extends up to the final temperature  $U_E$ .

## Electrical connections

### PT1000

Resistance table for PT1000

Ambient temperature and associated sensor resistance.

	0	1	2	3	4	5	6	7	8	9	0
-10	960,859	964,778	968,696	972,613	976,529	980,444	984,358	988,27	992,181	996,091	1000
0	1000	1003,908	1007,814	1011,72	1015,624	1019,527	1023,429	1027,33	1031,229	1035,128	1039,025
10	1039,025	1042,921	1046,816	1050,71	1054,603	1058,495	1062,385	1066,274	1070,162	1074,049	1077,935
20	1077,935	1081,82	1085,703	1089,585	1093,467	1097,347	1101,225	1105,103	1108,98	1112,855	1116,729
30	1116,729	1120,602	1124,474	1128,345	1132,215	1136,083	1139,95	1143,817	1147,681	1151,545	1155,408
40	1155,408	1159,27	1163,13	1166,989	1170,847	1174,704	1178,56	1182,414	1186,268	1190,12	1193,971
50	1193,971	1197,821	1201,67	1205,518	1209,364	1213,21	1217,054	1220,897	1224,739	1228,579	1232,419
60	1232,419	1236,257	1240,095	1243,931	1247,766	1251,6	1255,432	1259,264	1263,094	1266,923	1270,751
70	1270,751	1274,578	1278,404	1282,228	1286,052	1289,874	1293,695	1297,515	1301,334	1305,152	1308,968
80	1308,968	1312,783	1316,597	1320,411	1324,222	1328,033	1331,843	1335,651	1339,458	1343,264	1347,069
90	1347,069	1350,873	1354,676	1358,477	1362,277	1366,077	1369,875	1373,671	1377,467	1381,262	1385,055
100	1385,055	1388,847	1392,638	1396,428	1400,217	1404,005	1407,791	1411,576	1415,38	1419,143	1422,925
110	1422,925	1426,706	1430,485	1434,264	1438,041	1441,817	1445,592	1449,366	1453,138	1456,91	1460,68
120	1460,68	1464,449	1468,217	1471,984	1475,75	1479,514	1483,277	1487,04	1490,801	1494,561	1498,319
130	1498,319	1502,077	1505,833	1509,589	1513,343	1517,096	1520,847	1524,598	1528,347	1532,096	1535,843
140	1535,843	1539,589	1543,334	1547,078	1550,82	1554,562	1558,302	1562,041	1565,779	1569,516	1573,251
150	1573,251	1576,986	1580,719	1584,451	1588,182	1591,912	1595,641	1599,368	1603,095	1606,82	1610,544
160	1610,544	1614,267	1617,989	1621,709	1625,429	1629,147	1632,864	1636,58	1640,295	1644,009	1647,721
170	1647,721	1651,433	1655,143	1658,852	1662,56	1666,267	1669,972	1673,677	1677,38	1681,082	1684,783
180	1684,783	1688,483	1692,181	1695,879	1699,575	1703,271	1706,965	1710,658	1714,349	1718,04	1721,729
190	1721,729	1725,418	1729,105	1732,791	1736,475	1740,159	1743,842	1747,523	1751,203	1754,882	1758,56
200	1758,56	1762,237	1765,912	1769,587	1773,26	1776,932	1780,603	1784,273	1787,941	1791,609	1795,275

## 7 Notes on operation

### WARNING

**WARNING!**  
Moving parts can cause people in  
Violate the danger area.

Before starting up for the first time, ensure that all parts have been correctly assembled and that no persons can be endangered by the start-up.

Establish and maintain safety distances.

Install protective devices of the machine / system as far as possible before the trial run.

Observe the locally applicable safety rules / accident prevention regulations for trial operation (if any).

The strong permanent magnets on the rotor attract magnetic parts or particles that accumulate near the rotary joint. Additional electromagnetic fields also occur during operation.

## 8 Eccentric loads

If an eccentric load acts or could act on the bearing assembly, you must ensure that a failure of the power supply cannot lead to dangerous movements. For this it may be necessary to install protective devices.

# 9 Maintenance

Carry out all maintenance work only with the machine switched off. Make sure that there are no voltages on the torque motor. In the worst case, it can lead to an electric shock or an electric arc, which is life-threatening.

## 9.1 Maintenance safety notice

### Improper maintenance work

#### **WARNING**

#### **WARNING!**

**Risk of injury from improperly performed maintenance work!**

- Before cleaning and maintenance work, switch off the power supply to the drive and ensure that no parts can move dangerously.
- Before starting work, ensure that there is sufficient space for assembly.
- Make sure that the assembly area is tidy and clean!
- If components have been removed, ensure correct assembly, reinstall all fastening elements and adhere to the screw tightening torques.
- When cleaning the bearing, use suitable cleaning agents that are compatible with the seal. To do this, follow the instructions for the cleaning agent.
- Note the following before restarting:
  - Ensure that all maintenance work has been carried out and completed in accordance with the information and instructions in the manual.
  - Make sure that nobody is in the danger area.
  - Ensure that all covers and safety devices are installed and function properly.

### Incorrect maintenance

#### **NOTE**

#### **NOTE!**

**Property damage due to incorrect maintenance**

- Check the bearing assembly for corrosion every six months.
- Depending on the application (e.g. when influenced by vibrations), retighten the screw connections at regular intervals.
- If the bearing makes running noises, switch off the machine and determine the cause of the fault.
- Check the seals of the bearing at regular intervals.

## Bad lubrication

### NOTE

#### NOTE!

**Property damage to the warehouse due to improper Lubrication!**

- Only use greases approved by the manufacturer (see chapter 9.3 „Approved lubricants“).
- Observe the relubrication quantity and relubrication intervals (see chapter 9.3 „Relubrication“).
- Relubricate the bearing only at operating temperature.

## Environmental Protection

At all lubrication points that are supplied with lubricant, remove the escaping, used or excess grease and dispose of it in accordance with the applicable local regulations.

## 9.2 Cleaning

If the machine / system in which the bearing assembly with torque-motor is installed is to be cleaned, observe the following:

The bearings and motor are not protected against the ingress of moisture. Before cleaning work with liquids or a high-pressure cleaner, ensure that the bearing assembly with torque-motor is protected against the ingress of liquids.

## 9.3 Relubrication

### Lubricant



*Use fully synthetic lubricants for long-term lubrication due to their greater age resistance. Franke recommends the synthetic long-term grease Klüber ISOFLEX TOPAS NCA52.*

### NOTE

#### NOTE!

**Property damage due to improper lubrication!**

- Ensure that the lubricants are suitable for the respective application and for the materials used (e.g. roller bearing cages or seals).
- When mixing lubricants, take into account the compatibility of the lubricant types. Pay particular attention to the type of base oil, thickener, base oil viscosity and NGLI class. These questions must be clarified with the lubricant manufacturer in advance, especially if the bearing is used under extreme operating conditions.

# Maintenance

## Relubrication of the bearing

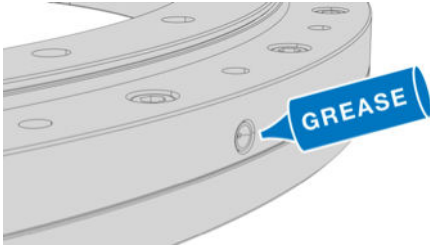

Fig. 06: Relubrication

1. Carry out relubrication at operating temperature of the bearing.
2. Turn the bearing when relubricating.



The relubrication interval is application-specific. The following table shows reference values.

Peripheral speed in [m / s]	Relubrication interval in (h)
0 to < 3	5000
3 to < 5	1000
5 to < 8	600
8 to < 10	200

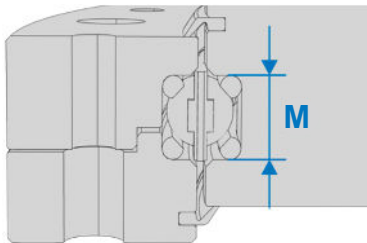

Fig. 07: Wire bed height

3. Once the relubrication frequency has been determined, calculate the relubrication amount using the following formula.

### Relubrication quantity:

$$m = KK\emptyset * (M * 2) / 3 * x$$

m = relubrication amount in grams

KK $\emptyset$  = spherical crown diameter

M = wire bed height in millimeters

x = factor x in mm<sup>-1</sup> according to the table for the relubrication amount

Wire bed height M:

LTD100: 9.2mm

LTD215: 12.86mm

LTD320: 15.5mm

LTD385: 15.5mm

LTD / CDC customer-specific: Refer to the drawing for relubrication

Relubrication	x in [mm <sup>-1</sup> ]
Weekly	0.002
Monthly	0.003
Yearly	0.004
Every 2-3 years	0.005

### 9.4 Retighten screw connections

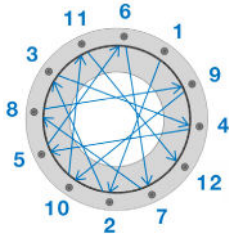

Fig. 08: Tighten the screws crosswise

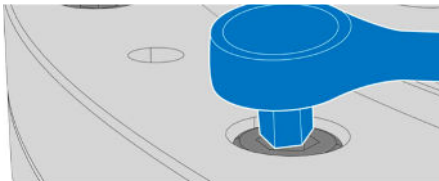

Fig. 09: Use a torque wrench

1. Tighten the screws crosswise with a torque wrench according to the specified tightening torques.



*The choice of fastening screws is determined by the designer.*

2. Check screws for signs of settlement after about 100 operating hours. Retighten screws if necessary.
3. Then check the screws every 600 hours of operation. The period is shortened under special operating conditions (e.g. vibrations).

### 9.5 Screw tightening torques

Screw size	Tightening torque in [NM] Strength class 8.8	Tightening torque in [Nm] Strength class 12.9
M6	10	17
M8	25	41
M10	49	83
M12	86	146
M16	215	363

### 9.6 Maintenance engine

Due to their structure and the way they work, torque-motors are generally wear-free.

The following maintenance work is necessary:

- Regularly check the freedom of movement and ease of movement of the bearing.
- Keep the engine compartment free from chips.
- Check current consumption regularly and compare with the first setting.
- Check the power cable regularly for tightness and damage.

The points listed should be checked at least every 2000 operating hours.

# 10 Declaration for the installation of a partly completed machine

In terms of Directive 2006/42 / EC Annex II Part 1 B and Supply of Machinery (Safety) Regulations 2008

Manufacturer name and address:

Franke GmbH  
Obere Bahnstrasse 64  
D-73431 Aalen

We hereby declare that the partly completed machine Bearing assembly with torque-motor type LTD / CDC as far as the scope of delivery allows, meets the basic requirements of the following guidelines. (Which requirements have been met, see below)

- Machinery Directive 2006/42 / EG
- EMC directives 2014/30 / EU

Applied harmonized standards, the references of which have been published in the Official Journal of the EU:

EN ISO 12100-11 / 2010 Safety of machinery - General principles for design - Risk assessment and risk minimization.

Furthermore, we declare that the special technical documents for this incomplete machine were created in accordance with Annex VII Part B and we undertake to forward them to the market surveillance authorities via our documentation department on request.

Commissioning of the incomplete machine is prohibited until the incomplete machine has been installed in a machine that complies with the provisions of the EC Machinery Directive and for which an EC declaration of conformity in accordance with Appendix II 1 A is available.

The person who signed this declaration is authorized to compile the technical documents.

This declaration of incorporation was issued in / on / by:

Aalen, September 06, 2022



Jörg Egelhaaf (Technical Manager)



## 10.1 Appendix to the declaration for the installation of a partly completed machine

Requirements of Annex I of 2006/42 / EC that have been met. The Numbers refer to the sections of Annex I:

- 1.1.2 Principles for integrating security
- 1.1.3 Materials and Products
- 1.1.5 Construction of the machine with a view to handling
- 1.3.1 Risk of loss of stability
- 1.3.9 Risk of uncontrolled movements
- 1.5.1 Electrical energy supply
- 1.5.5 Extreme temperatures
- 1.5.10 Radiation
- 1.7.2 Warning of residual risks
- 1.7.4.2 Content of the operating instructions (partially)

# 11 Attachment

## Data tables

LTD100

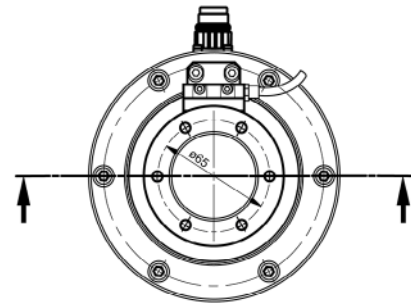
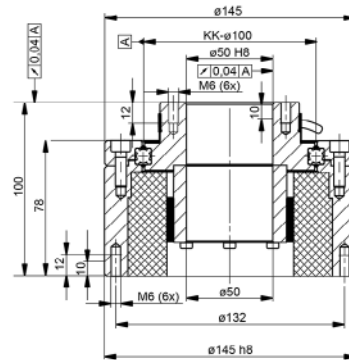

LTD215

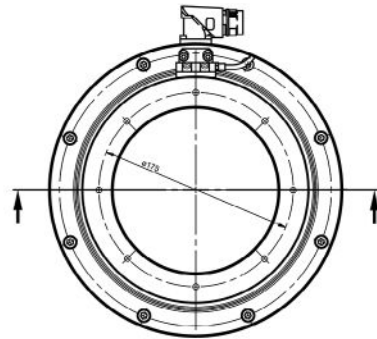
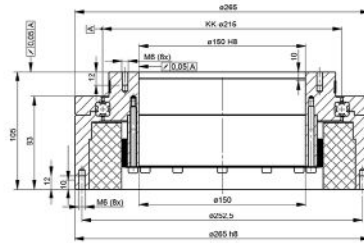

LTD320

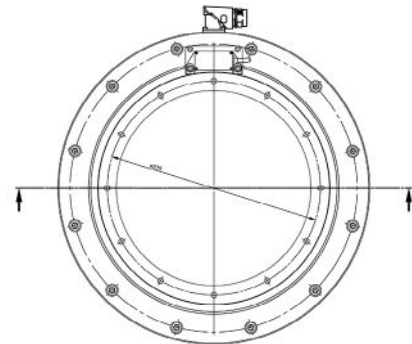
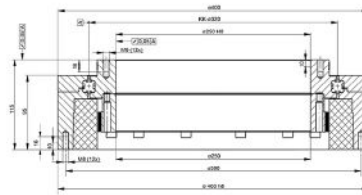

LTD385

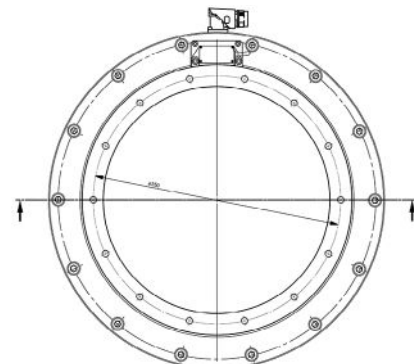
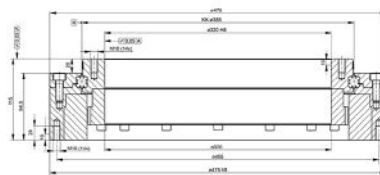

Name	KK Ø mm	Load ratings kN				Weight kg	Order no.
		C <sub>0a</sub>	C <sub>0r</sub>	C <sub>a</sub>	C <sub>r</sub>		
LTD-100	100	46	22	17	14	8	609818
LTD-215	215	128	60	26	22	21	609885
LTD-320	320	382	180	45	39	44	609886
LTD-385	385	458	216	48	41	57	609913

Power comparison			LTD-100	LTD-215	LTD-320	LTD-385
<b>Nominal Data (free air convection)</b>						
Nominal Torque	T <sub>NomAC</sub>	Nm	4,5	26,4	77	118
Nominal Current	I <sub>NomAC</sub>	A <sub>rms</sub>	1,8	3,1	4,3	4,3
Nominal Speed	n <sub>NomAC</sub>	rpm	2140	640	299	193
Nominal Power	P <sub>NomAC</sub>	W	1005	1770	2409	2386
Winding Losses <sup>1</sup>	P <sub>V<sub>DAC</sub></sub>	W	54	131	230	309
Total Losses <sup>2</sup>	P <sub>DAC</sub>	W	96	179	295	357
Holding Torque	T <sub>HAC</sub>	Nm	3,2	18,7	54	83
Holding Current	I <sub>HAC</sub>	A <sub>rms</sub>	1,2	2,2	3	3
<b>Peak Data</b>						
Peak Torque	T <sub>Peak</sub>	Nm	16	105	329	522
Peak Current	I <sub>Peak</sub>	A <sub>rms</sub>	7	12,8	21,6	21,7
Speed at Peak Torque	n <sub>Peak</sub>	rpm	1130	320	126	74
Peak Power	P <sub>Peak</sub>	W	1897	3526	4343	4049
Winding Losses <sup>1</sup>	P <sub>Peak</sub>	W	863	2236	5886	7876
Total Losses <sup>2</sup>	P <sub>D<sub>Peak</sub></sub>	W	877	2253	5904	7889
<b>Power Data</b>						
Torque Constant	kt	Nm/A <sub>rms</sub>	2,549	8,51	18,037	27,449
		V <sub>rms</sub> /(rad/s)	1,577	5,2	11,094	16,694
BEMF Constant (Phase - Phase)	k <sub>e</sub>	V <sub>rms</sub> /(rpm)	0,165	0,545	1,162	1,748
Motor Constant	km	Nm/VV	0,459	1,973	4,483	6,25
Idle Speed	n <sub>idle</sub>	rpm	2390	727	340	226
max. Speed (Fieldweaking)	n <sub>max</sub>	rpm	-	-	-	-
max. Frequency (Idle/Fieldweaking)	f <sub>max</sub>	Hz	398	254	159	124
DC Bus Voltage	UDC	VDC	560	560	560	560
Ø Resistance per Phase (winding only)	R <sub>Ph20</sub>	Ω	4,419	3,457	3,206	4,235
Ø Inductance per Phase (winding only)	L <sub>Ph</sub>	mH	21,727	19,532	21,071	28,049
electr. Time Constant t=L/R	Tei	ms	4,92	5,65	6,57	6,62
Number of Polepairs	n		10	21	28	33
Winding Connection			Star	Star	Star	Star
<b>Measuring System</b>						
Measuring Method					incremental	
Reference mark					single coded	
Measuring principle					inductive	
Interface					1 Vpp	
Cable length					1 m	
Grating period					1000 µm	
Line count			256	640	938	1200
Interpolation					10-fold	
Number of signal periods			2560	6400	9380	12000
Position error per grating period			±11"	+4,5"	+3"	+2,5"
Grating period accuracy (±10µm arc length)			±51"	±20"	±14"	±11"
Max. scanning frequency					40 kHz	
Voltage supply					4V to 7V DC	
Electrical connection					cable with M23, 12 pin male	

### Annotations

<sup>1</sup>Winding Losses are referred to a Coil Temperature of 100°C.

<sup>2</sup>The total Losses are made up of: Winding Losses; Stator Iron Losses; Rotor Losses; Calculation of total Losses: Winding Losses + Stator Iron Losses (at speed X) + Rotor Losses (at speed X)

Ensure that your servo drive can handle the Nominal- and Peakcurrent of the Motor. An adjustment of the Speed and DC Bus Voltage can be done after consultation. The nominal data in this datasheet are based on an ambient/coolant temperature of 20°C The stated nominal Torques are without consideration of friction losses through Bearings or Sealings.

Because the exact duty type depends also on the thermal connection of the motor, the embedded thermal monitoring system has to be analysed and attented. However, attention has to be payed that the temperature sensors do not show the exact temperature of the winding and this could be up to 20 K higher due to thermal capacities. Despite an electrical insulation towards the winding, you are only allowed to connect the sensors to your controller by using a galvanic separation in between.