

# Standard program

**Wire Race Bearing Slim Bearings Bearing Assemblies Rotary Tables**  
**Linear Guides Linear Tables Linear Modules**

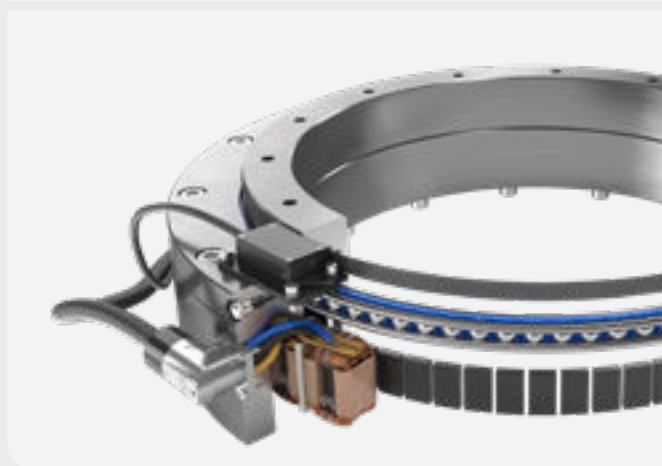

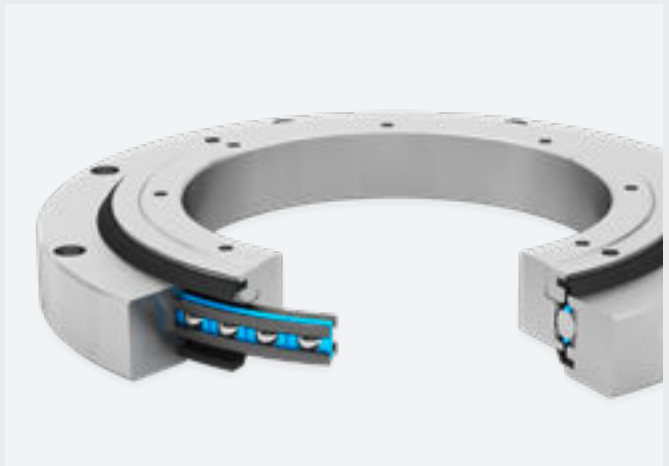
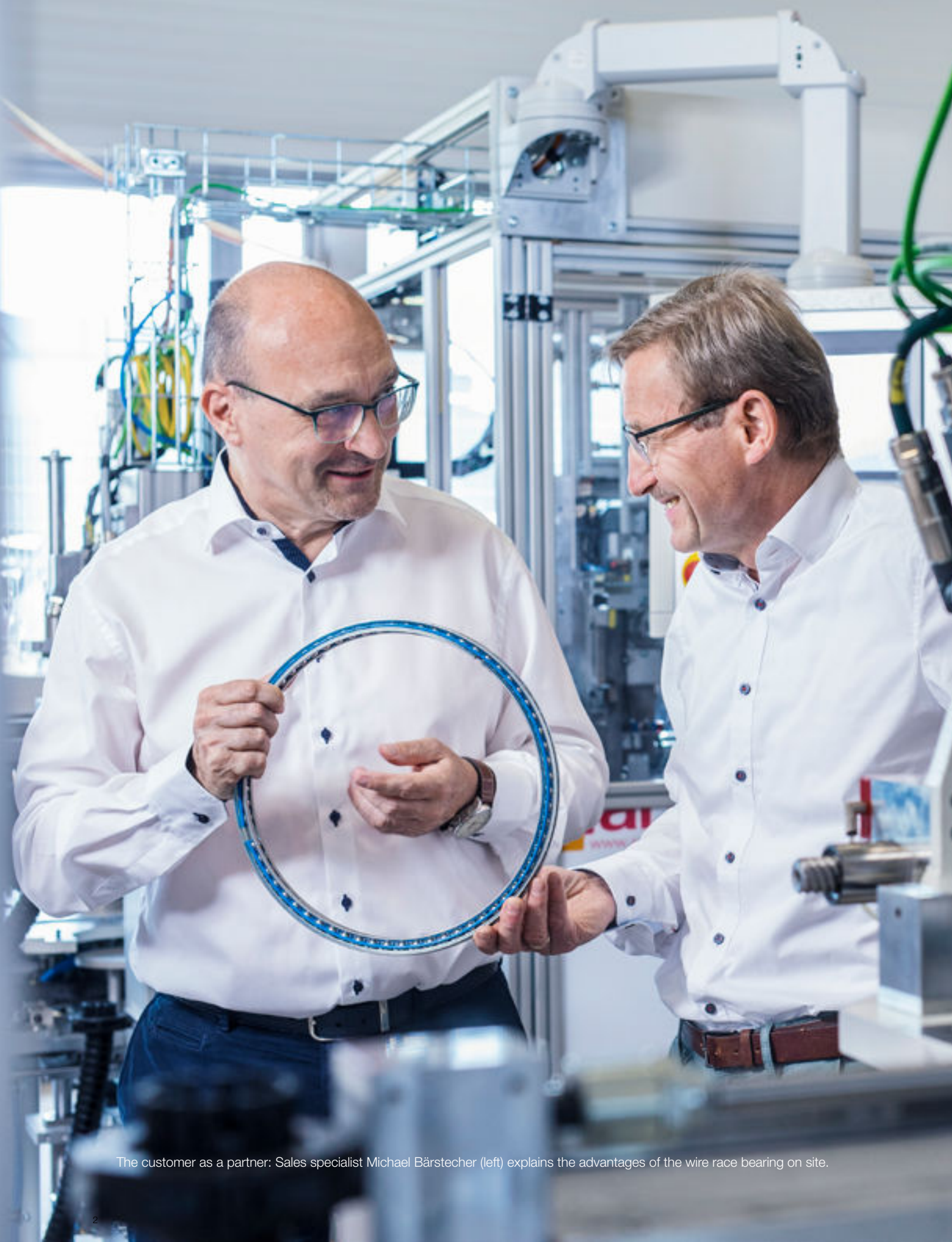

The customer as a partner: Sales specialist Michael Bärstecher (left) explains the advantages of the wire race bearing on site.

## The principles of our actions

Franke is the inventor of the wire race bearing and a world leader in the further development and use of this technology in rotary and linear motion systems. We are the market leader in customized bearing solutions. We focus on applications where our products offer the greatest possible benefits. Resources are targeted by us to continuously increase our competence.

Our corporate principles place the „what for“ at the center of our considerations:

1

### Why do we do it?

We want to move things: technical innovations, the development of personal potential and the development of good human relationships.

2

### How do we do it?

We support our clients super-individually with our creativity, expertise and care at every stage of the collaboration.

3

### What do we do?

We develop and produce ideally fitting bearing solutions for rotary and linear applications - including consulting, engineering and service.

# This is what we stand for

With our brand values we define what Franke is all about and what our strengths are. We can always refer to these values. They give us orientation in our work-life and on our path into the future.



## Innovation

We work to always provide customers with optimal bearing solutions and to systematically open up new markets for wire race bearings and linear systems. With our solutions, we help our customers to be innovative. To this end, we follow technological trends and develop new products. We regularly and significantly invest in modern technologies and in the continuous improvement of internal structures, processes and procedures. In this way, we create an innovation-friendly environment. We regard a willingness to change and lifelong learning as the basis for innovation.

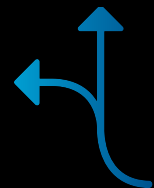

## Agility

We are an active, consulting partner to our customers and work with them to find the best possible solutions at all levels of cooperation. Our structures allow us to react quickly and flexibly. Modern control systems allow the variable use of resources for individual and series production. We work in effective teams whose interaction is characterized by short paths of decisions. The outsourcing of production tasks, flexible working hours and situation-related personnel deployment enable us to quickly adapt our performance to demand.



## Competence

Franke is the inventor of the wire race bearing and a world leader in the further development and use of this technology in rotary and linear motion systems. A comprehensive understanding of the technical and economic challenges of our customers in all industries is fundamental to our success. This is complemented by manufacturing know-how and excellent product and manufacturing development as further supporting pillars. Our performance is also supported by a qualified and reliable network of partners and institutes.



## Reliability

Reliability is a core value for us in all our relationships. We want to be reliable for our customers, for our colleagues and for everyone around us. Clear management processes, consistent targets and solid key figures help us to be valued as reliable players. We earn our customers' trust with outstanding delivery performance, reliable products and comprehensive service. In our dealings with each other, we meet deadlines and commitments and provide feedback on the status and progress of joint projects. For us, reliability also means trusting the work of others and helping to avoid mistakes.



## Team Spirit

We are convinced that we can achieve more together. To this end, we form flexible teams. We regard our customers and external partners as members of our team. For us, team spirit includes mutual appreciation, interest in the perspectives of our fellow human beings and recognition for their achievements. We cultivate respectful, appreciative interaction with each other. Differing opinions are important and welcome in the decision-making process. In the event of conflicts, we strive for compromises and joint solutions.

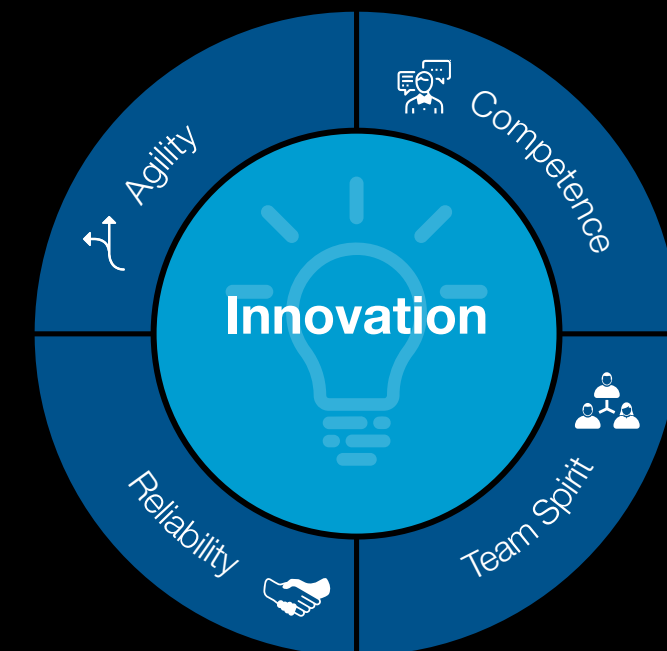



In close contact with our customers: Ignacio Garcia (r.) from Franke Spain provides valuable tips on site.



**Wire Race Bearing Slim Bearings Bearing Assemblies Rotary Tables**

**Linear Guides Linear Tables Linear Modules**

## Wire Race Bearings

	Type	Page	Characteristics
	<b>Bearing Elements</b> LEL LER LEW	14 15 16	Round profile, ground raceways Rectangular profile, profiled raceways Round profile, crossed roller bearings
	<b>Slim Bearings</b> LSA	17	2-ring bearing, drawn profile
	<b>Bearing Assemblies</b> LVA/LVB/LVK LVD/LVL LVE/LVM LVE/LVG	18 19 20 21	Standard, steel/aluminum/plastic External toothing, steel/plastic Toothed belt toothing, aluminum/plastic Angular contact ball bearing, angular contact roller bearing
	<b>Rotary Tables Rotary Systems</b> LTA LTB LTD	22 23 24	Worm drive, highly dynamic Worm drive, high precision Torque drive, dynamic and precise

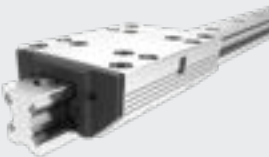
## Linear Systems

	Type	Page	Characteristics
	<b>Linear Guides</b> FDA/FDB/FDC/ FDD/FDE/FDG/ FDH/FDI	30	Double rail with cassette Pair of single rails and pair of roller shoes
	<b>Linear Tables Linear Modules</b> FTB FTC FTD	33 34 35	Spindle Drive, Metallabdeckung Toothed belt or spindle drive Toothed belt drive

# Four wires for better design: Franke Wire Race Bearings



The decisive difference between an ordinary ball bearing and a Franke wire race bearing is in the raceways. In a wire race bearing, the rolling elements do not roll on solid housing rings, but on high performance wires. The flexibility of this principle makes it possible to design more freely and simply, in order to develop better products.

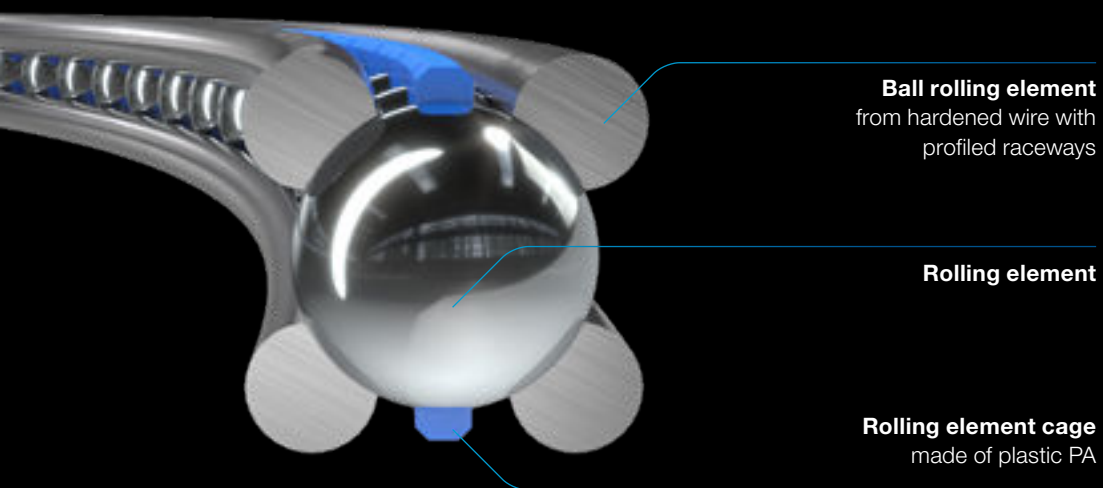

**Ball rolling element**  
from hardened wire with  
profiled raceways

**Rolling element**

**Rolling element cage**  
made of plastic PA

In a wire race bearing, highly resilient bearing rings made of wire assume the function of the bearing arrangement. This saves weight and space. The free choice of material and the free design of the enclosing structure also allow the weight of the overall product to be reduced considerably.

In wire race bearings, the raceways of the rolling elements are precisely matched to the diameter of the rolling elements. This ensures optimum functional characteristics and guarantees both, precise running and a long operating life.

## Anything you wish. Only what you need.

You can purchase from Franke only the bearing elements or ready-to-install bearing assemblies. On request in customer-specific design, with toothing or with integrated torque motor.



### Bearing Elements & Slim Bearings

All you need for your product solution with wire race bearings is a Franke bearing element. Franke bearing elements can be integrated directly into your design. You can easily assemble them yourself. The bearing element can be adapted in form and material bespoke to your requirements, for example by choosing amagnetic ceramic rolling elements.



### Bearing Assemblies

If required, we can also design and manufacture complete bearing assemblies for you. These can be mounted even more easily than bearing elements. Franke bearing assemblies are available in every size, with individual bores and toothings and in numerous materials such as aluminum, stainless steel, carbon or as a 3D printed housing.



### Rotary Tables Rotary Systems

You prefer a complete solution from one source? Franke offers complete customized positioning and drive units, optionally with proximity switch, coupling and motor. Systems with direct drive are a particular strength of Franke. They are used, for example, in many computer tomographs of renowned manufacturers.

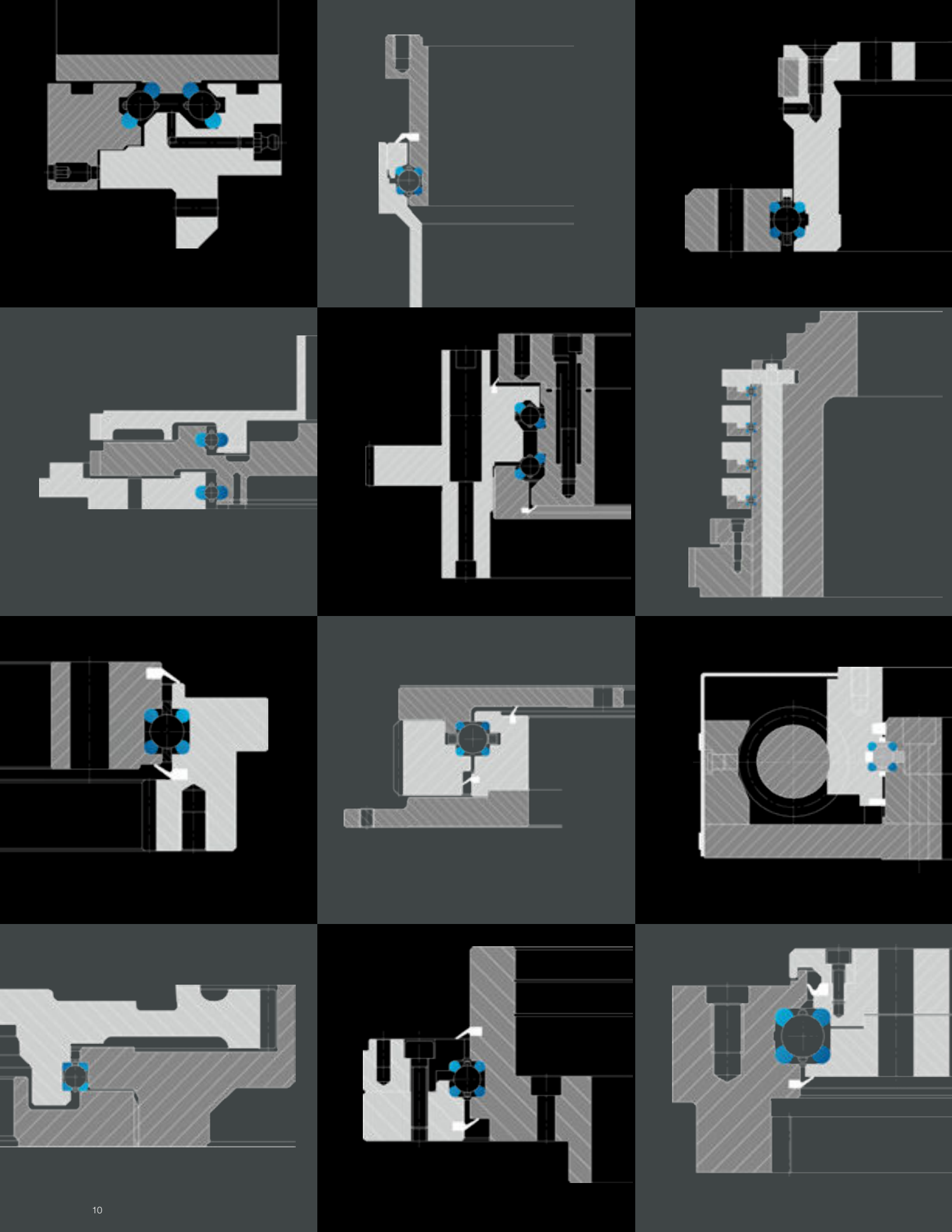

## Possibilities instead of specifications

Franke wire race bearings are space-saving, variable and individually adaptable. This gives you the greatest possible freedom for innovative solutions.

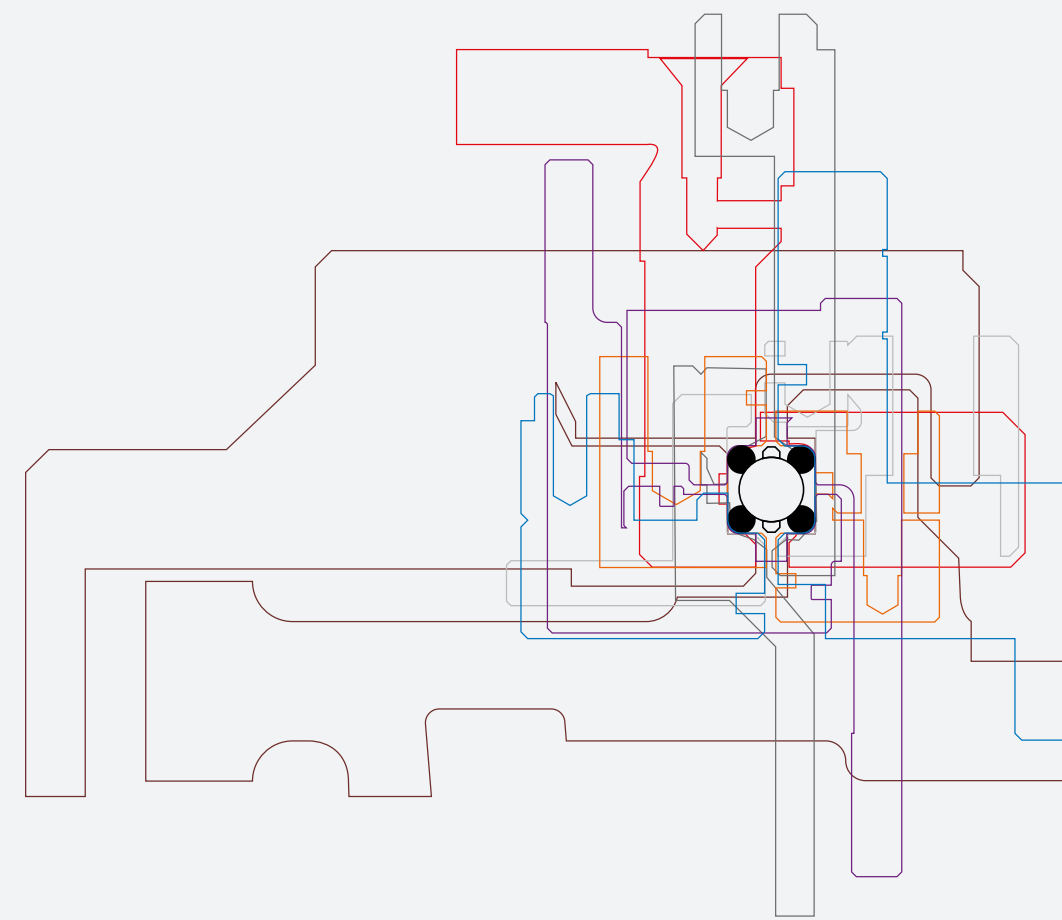

# Superindividual

## Individualization with the Franke modular system

All you need for your product solution with Franke ball bearings is a wire race bearing. Franke bearing elements can be integrated directly into your design. The shape and material of wire race bearings can be adapted to your requirements in a highly individual way. Here you will find examples.

### Rolling element



Ball Roller Special designs

### Raceways



Round profile Rectangular profile Slim bearings Roller bearing 4-point contact bearing 2-row angular contact ball bearing

### Standard cages



Ball cage Roller cage Flat cage Comb cage Steel / Teflon / Brass / ...

### Special designs

### Verzahnungen

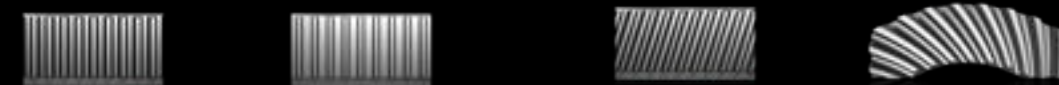

Straight Gear Toothed Belt Gear Helical Gear Special Gear

### Dichtungen



Labyrinth seal Ring spring seal Radial shaft seal High pressure seal

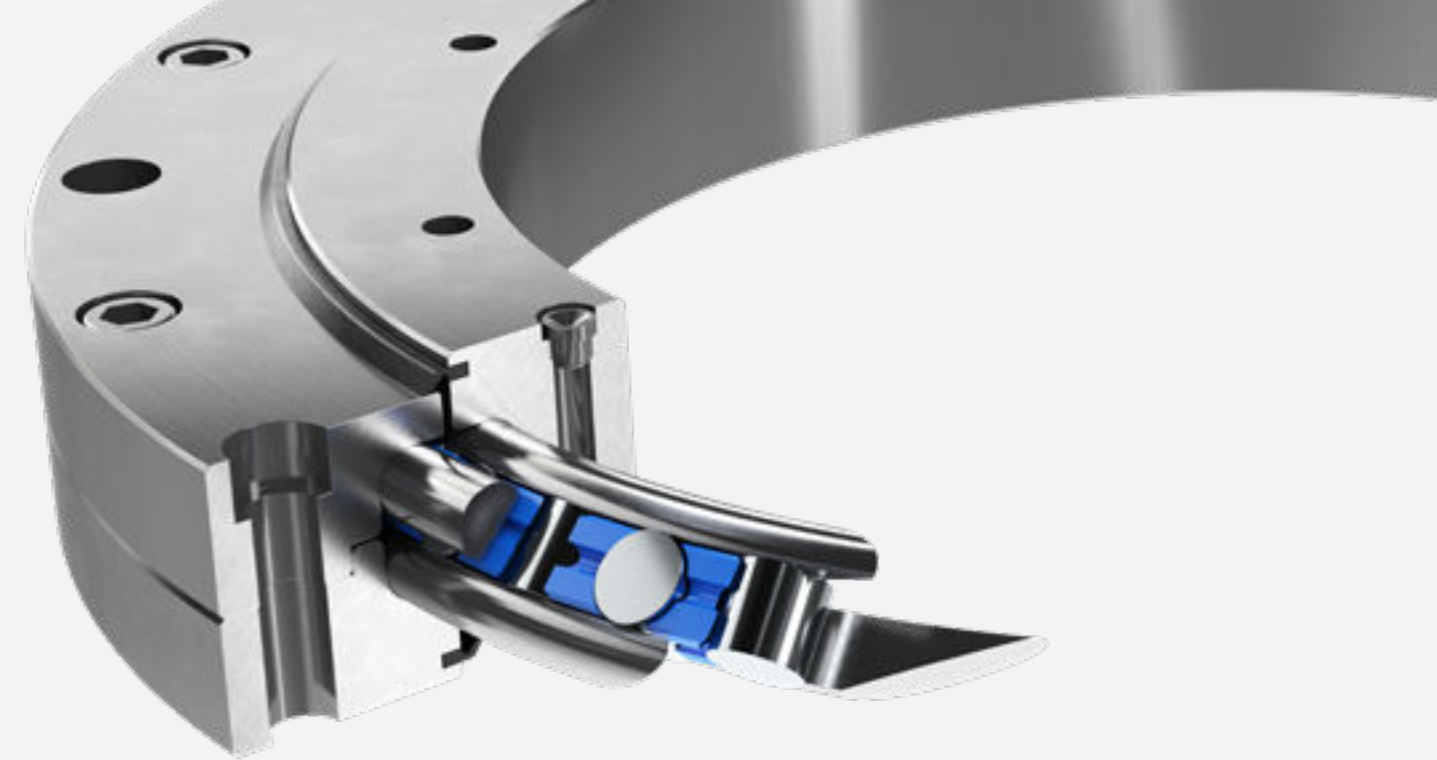

## Tough on the road

Crossed roller bearings for maximum rigidity and moment load capacity.

Crossed roller bearings with hardened races are extremists: They can withstand the highest moment loads, shock loads and vibrations and thus advance into regions that were previously unattainable for wire race bearings. The machining of hardened races requires completely new technologies. Together with the application-specific design of the enclosing construction, this creates rotary components for the toughest applications. For example, in the storage of heavy equipment on vehicles or means of transport for any terrain, under continuous load with high tilting moments, such as in radar systems, or in the suspension of complex ceiling lights in medical technology.



Large cross-section races have a large contact area with the rolling elements and thus ensure optimum absorption of the loads.



Large-diameter, cross-mounted track rollers provide the best possible contact surface to absorb loads from all directions and provide uniformly smooth running.

# Bearing elements with a ground raceway

## Type LEL

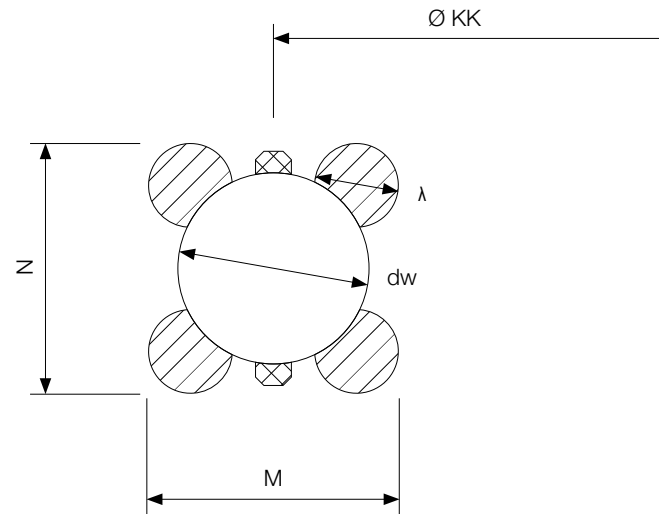

### Dimensions

Size	Dimensions mm				Load ratings kN				stat. Moment kNm	Weight kg
	Ø KK	M x N	dw	λ	C <sub>oa</sub>	C <sub>or</sub>	C <sub>a</sub>	C <sub>r</sub>		
LEL1.5	70 - 150	5.9 x 5.9	5	1,5	14 - 30	6 - 14	8 - 10	7 - 9	0.2 - 1	0.03 - 0.06
LEL2.5	160 - 300	9.2 x 9.2	8	2,5	73 - 141	35 - 66	20 - 25	17 - 22	2.8 - 9.9	0.15 - 0.29
LEL4	200 - 1500	12.86 x 12.86	9.525	4	117 - 908	55 - 427	25 - 53	21 - 46	5.5 - 320.3	0.39 - 2.91
LEL5	220 - 1500	15.5 x 15.5	12	5	257 - 1782	121 - 839	41 - 83	35 - 72	13 - 629	0.70 - 4.77
LEL7	340 - 2000	20.9 x 20.9	16	7	470 - 2811	221 - 1323	59 - 113	51 - 98	37.6 - 1323.1	1.86 - 10.98

### Characteristics

Franke bearing elements of type LEL are suitable for high demands on running characteristics and accuracy. Due to the hardened and CNC-ground raceway as well as the ideal geometrical adaptation of ball and raceway radius, they have outstanding bearing characteristics. Bearing elements of type LEL allow the greatest possible freedom of bearing design. The mounting space is between 5.9 mm and 20.9 mm. For special requirements, raceway thicknesses up to 20 mm and ball sizes up to 50 mm are possible.

### Technical data

**Material** ball race rings: hardened and tempered chrome-silicon steel  
 rolling element: hardened rolling bearing steel  
 cage: polyamide or thermoplastic polyurethane

**Operating temp.** -30 °C to +80 °C, briefly up to +100 °C

**Peripheral speed.** max. 5 m/s, without seals max. 10 m/s

**Lubricant** Klüber ISOFLEX TOPAS NCA52 (recommended)

### Design example

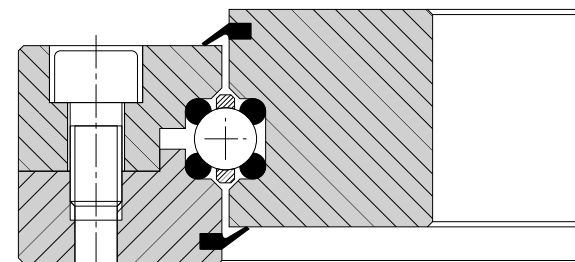

# Bearing elements with profiled raceways

## Type LER

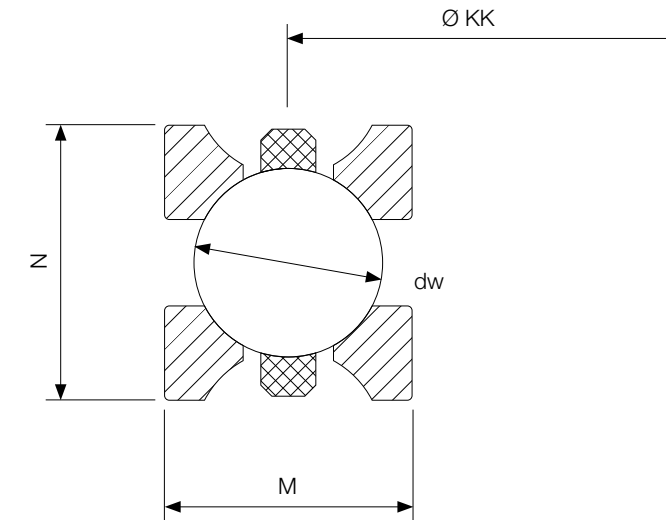

### Dimensions

Size	Dimensions mm			Load ratings kN				stat. Moment kNm	Weight kg
	Ø KK	M x N	dw	C <sub>oa</sub>	C <sub>or</sub>	C <sub>a</sub>	C <sub>r</sub>		
LER1.5	40 - 150	5 x 6	4	8 - 33	4 - 15	5 - 8	4 - 7	0.1 - 1.2	0.01 - 0.06
LER2	80 - 400	7.5 x 9	6	28 - 143	13 - 67	11 - 19	9 - 17	0.5 - 13.5	0.06 - 0.33
LER3	100 - 1500	11 x 13	9.525	54 - 850	25 - 399	18 - 49	15 - 43	1.3 - 300	0.17 - 2.58
LER4	200 - 1500	14 x 16	12	175 - 1346	82 - 633	40 - 84	34 - 73	8.2 - 474.9	0.61 - 4.58
LER5	250 - 1800	15.75 x 17.5	12	260 - 1922	123 - 905	43 - 90	37 - 78	15.3 - 814	0.94 - 6.79

### Characteristics

Franke bearing elements type LER are suitable for medium rotational speeds and accuracies. They convince by smooth running, high dynamics and compact installation space. Due to the straight contact surfaces, they can be easily integrated into the surrounding design and have a high rigidity. The low price makes the bearing element of type LER an economical solution. LER are generally mounted without clearance. The preload can be individually adjusted according to the requirements.

### Technical data

**Material** ball race rings: hardened and tempered chrome-silicon steel  
 rolling element: hardened rolling bearing steel  
 cage: polyamide or thermoplastic polyurethane

**Operating temp.** -30 °C to +80 °C, short-term up to +100 °C

**Peripheral speed.** max. 5 m/s, without seal max. 10 m/s

**Lubricant** Shell Gadus S3 V220 C2

### Design example

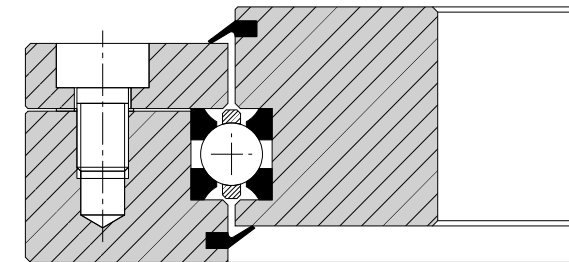



# Crossed roller bearings with ground raceways Type LEW

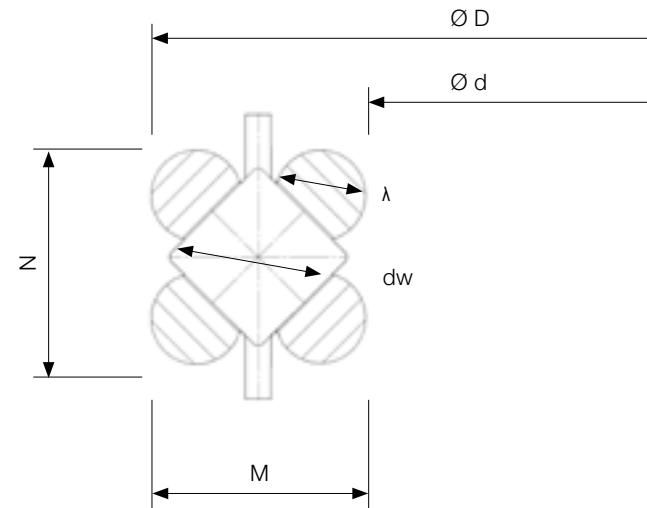

## Dimensions

Size	Dimensions mm				Load ratings kN				stat. Moment kNm	Weight kg
	Ø KK	M x N	dw	z	C <sub>oa</sub>	C <sub>or</sub>	C <sub>a</sub>	C <sub>r</sub>		
LEW7	400 - 1200	16.6 x 16.6	7	7	350 - 1074	140 - 430	90 - 234	47 - 122	28.2 - 258	1.9 - 5.5

## Characteristics

Franke bearing elements type LEW are suitable for medium rotational speeds and accuracies. They convince by smooth running even under tilt moment loads, high rigidity and compact installation space. The crosswise arranged rollers can support high loads from all directions. Bearing elements of model LEW are insensitive to shock and vibration. They offer the greatest possible flexibility in terms of preload, running characteristics and diameter ranges.

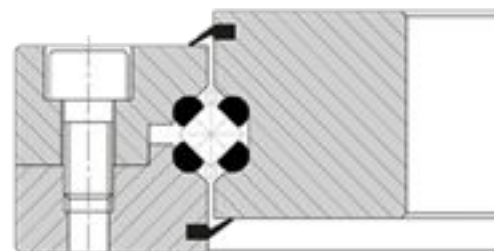

## Technical data

<b>Material</b>	ball race rings: hardened and tempered chrome-silicon steel rolling element: hardened rolling bearing steel cage: polyamide or thermoplastic polyurethane
<b>Operating temp.</b>	-30 °C to +80 °C, short-term up to +100 °C
<b>Peripheral speed.</b>	max. 4 m/s
<b>Lubricant</b>	Shell Gadus S3 V220

# Slim bearings with profiled raceways Type LSA

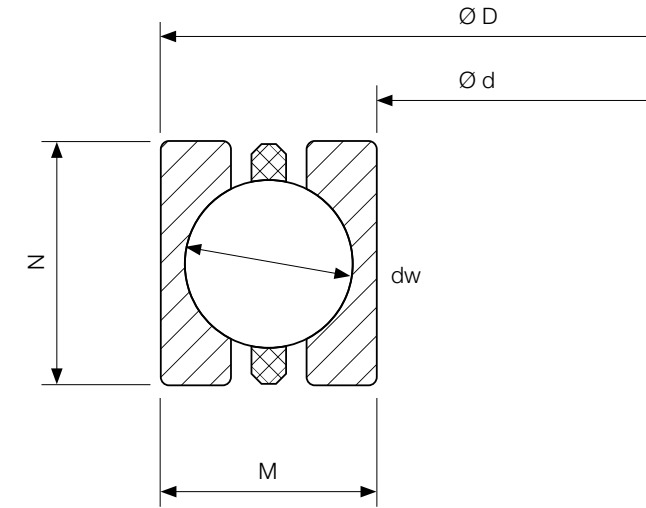
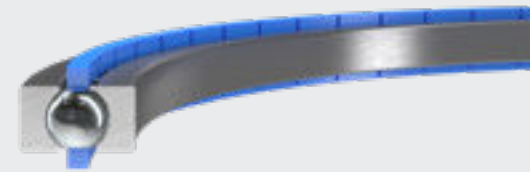

## Dimensions

Size	Dimensions mm					Load ratings kN				stat. Moment kNm	Weight kg
	Ø d inch	Ø D	Ø d	M x N	dw	C <sub>oa</sub>	C <sub>or</sub>	C <sub>a</sub>	C <sub>r</sub>		
LSA4	4.0 - 15	115.68 - 395.08	101.6 - 381	7.04 x 4	4	25 - 95	12 - 45	7 - 10	6 - 8	0.6 - 9	0.05 - 0.19
LSA6	4.5 - 15	127 - 393.8	114.3 - 381	6.4 x 6.4	4	39 - 129	18 - 61	7 - 11	6 - 9	1.3 - 11.7	0.09 - 0.29
LSA8	5.5 - 30	155.7 - 778	139.7 - 762	8 x 7.94	5	59 - 311	28 - 146	13 - 23	11 - 20	2 - 56.3	0.17 - 0.91

## Characteristics

Franke slim bearings of the type LSA convince by their smooth running, extremely compact installation space, simple mounting and favourable price. Slim bearings of type LSA consist of an inner and outer race with hardened and profiled raceways and a plastic cage with retained balls. The rolling elements rest against the raceways at two points each, thus maintaining the 4-point system. The raceways are split and can therefore be changed elastically in diameter for installation.

## Design example

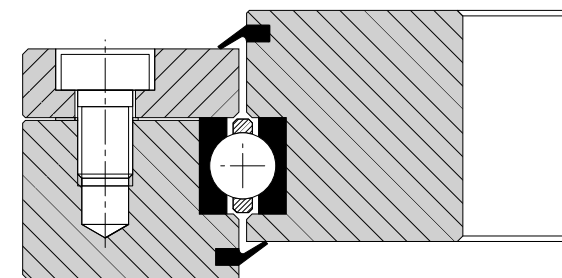

## Technical data

<b>Material</b>	ball race rings: hardened and tempered chrome-silicon steel rolling element: hardened rolling bearing steel cage: polyamide or thermoplastic polyurethane
<b>Operating temp.</b>	-20 °C to +80 °C, short-term up to +100 °C
<b>Peripheral speed.</b>	max. 5 m/s, without seal max. 10 m/s
<b>Lubricant</b>	Shell Gadus S3 V220

## Bearing assemblies in standard version Type LVA, LVB, LVK

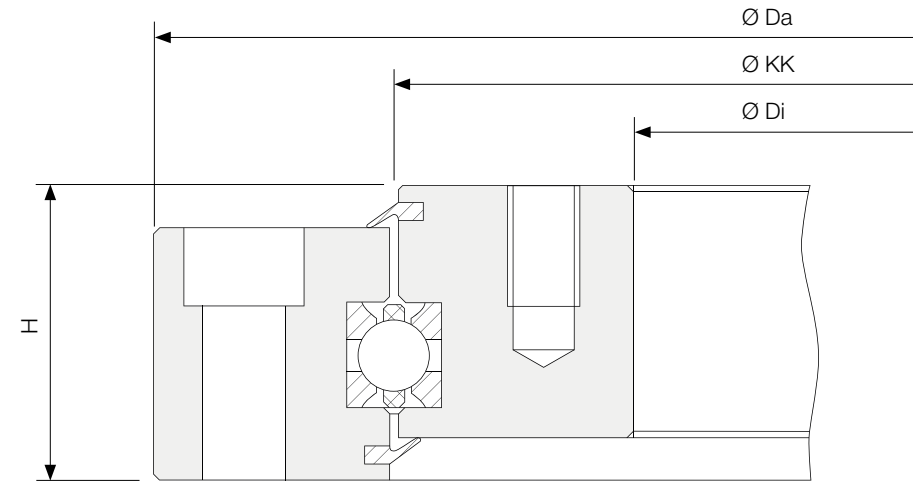

### Dimensions

Type	Material Housing rings	Dimensions mm				Load ratings kN				stat. Moment kNm	Weight kg
		Ø KK	Ø Da	Ø Di	H	C <sub>oa</sub>	C <sub>or</sub>	C <sub>a</sub>	C <sub>r</sub>	C <sub>om</sub>	
LVA	Steel	100 - 1800	150 - 1930	50 - 1670	34 - 90	54 - 2234	25 - 1050	18 - 146	15 - 126	1 - 946	3 - 449
LVB	Aluminum	100 - 1800	150 - 1930	50 - 1670	34 - 90	54 - 2234	25 - 1050	18 - 146	15 - 126	1 - 946	1.2 - 166.7
LVK	Plastic	150 - 200	150 - 250	50 - 150	20	5.6 - 10.6	2 - 3.8	5.6 - 10.6	2 - 3.8	0.07 - 0.25	0.5 - 1

### Characteristics

Franke Bearing Assemblies Type LVA, LVB and LVK are ready-to-install bearing assemblies with housing rings made of steel (LVA), aluminum (LVB) or plastic (LVK) and integrated bearing elements. Designed as 4 point bearings, they can support equally high loads from all directions and are insensitive to shocks and vibrations. LVA and LVB bearing assemblies are sealed on both sides. All Franke Bearing Assemblies are adjusted with preload.

### Technical data

		LVA (steel)	LVB (aluminum)	LVK (plastic)
<b>Material</b>	Inner / Outer ring:	C45N	aluminum (anodized)	polyoxymethylene (POM)
	Ball race rings:	hardened and tempered chrome-silicon steel		non corrosive Steel (1.4310)
	Rolling element:	hardened rolling bearing steel		non corrosive Steel
	Cage:	polyamide or thermoplastic polyurethane		polyamid (PA12)
	Sealing:	NBR		-
<b>Operating temp.</b>		-20 °C to +80 °C, short-term up to +100 °C		
<b>Peripheral speed.</b>		max. 5 m/s, without seal max. 10 m/s		
<b>Lubricant</b>		Shell Gadus S3 V220 C2		
<b>Relubrication</b>		via grease nipples to DIN 3405		

## Slewing rings with external teeth Type LVD, LVL

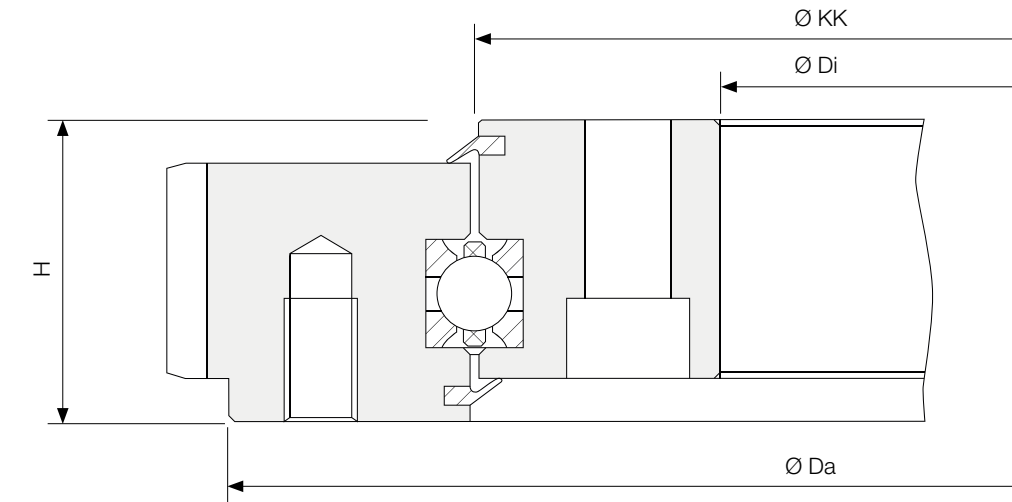
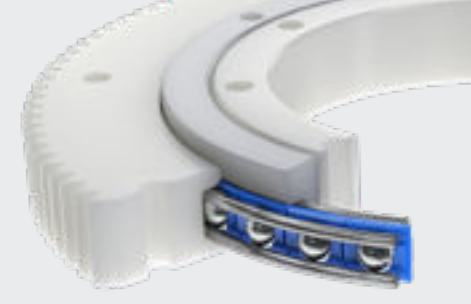

### Dimensions

Type	Material Housing rings	Dimensions mm				Load ratings kN				stat. Moment kNm	Weight kg
		Ø KK	Ø Da	Ø Di	H	C <sub>oa</sub>	C <sub>or</sub>	C <sub>a</sub>	C <sub>r</sub>	C <sub>om</sub>	
LVD	Steel	100 - 1800	150 - 1930	50 - 1670	27 - 82	54 - 2234	25 - 1050	18 - 146	15 - 126	1 - 946	3.4 - 484.2
LVL	Plastic	100 - 200	150 - 250	50 - 150	24	5.6 - 10.6	2 - 3.8	2.6 - 10.6	2 - 3.8	0.07 - 0.25	0.5 - 1

### Characteristics

Franke bearing assemblies type LVD and LVL are ready-to-install bearing assemblies with housing rings made of steel (LVD) or plastic (LVL), integrated bearing elements and external gear. Designed as 4-point bearings, they can support equally high loads from all directions and are insensitive to shocks and vibrations. LVD bearing assemblies are sealed on both sides. All Franke bearing assemblies are adjusted to preload.

### Technical data

		LVD (steel)	LVL (plastic)
<b>Material</b>	Inner / Outer ring:	C45N	polyoxymethylene (POM)
	Ball race rings:	hardened and tempered chrome-silicon steel	non corrosive Steel (1.4310)
	Rolling element:	hardened rolling bearing steel	non corrosive Steel
	Cage:	polyamide or thermoplastic polyurethane	polyamid (PA12)
	Sealing:	NBR	-
<b>Gear</b>		DIN 3967, quality 8e25, straight toothing	
<b>Operating temp.</b>		-20 °C to +80 °C, short-term up to +100 °C	
<b>Peripheral speed.</b>		max. 5 m/s, without seal max. 10 m/s	
<b>Lubricant</b>		Shell Gadus S3 V220 C2	
<b>Relubrication</b>		via grease nipples to DIN 3405	

# Bearing assemblies with toothed belt gearing Type LVE, LVM

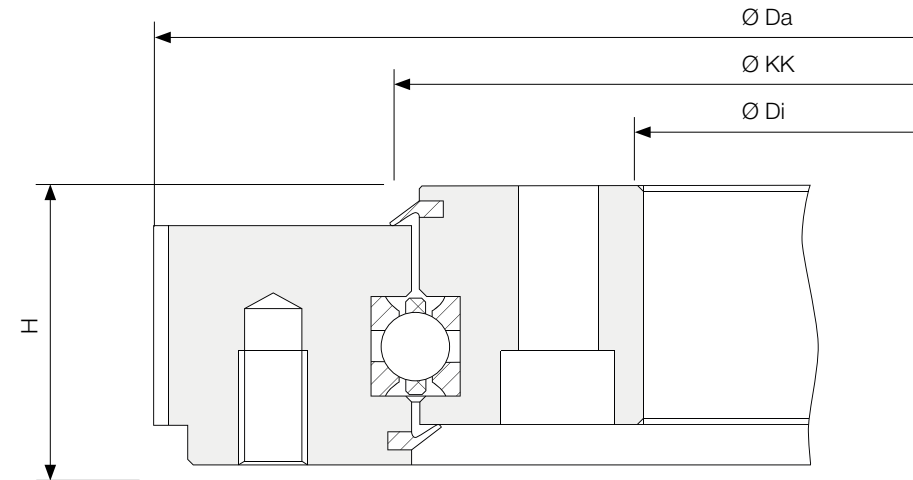

### Dimensions

Type	Material Housing rings	Dimensions mm				Load ratings kN				stat. Moment kNm	Weight kg
		Ø KK	Ø Da	Ø Di	H	C <sub>oa</sub>	C <sub>or</sub>	C <sub>a</sub>	C <sub>r</sub>		
LVD	Aluminum	100 - 1800	150 - 1930	50 - 1670	27 - 82	54 - 2234	25 - 1050	18 - 146	15 - 126	1 - 946	1.2 - 166.7
LVM	Plastic	100 - 200	150 - 250	50 - 150	24	5.6 - 10.6	2 - 3.8	2.6 - 10.6	2 - 3.8	0.07 - 0.25	0.5 - 1

### Characteristics

Franke bearing assemblies Type LVE (aluminum) and LVM (plastic) are ready-to-install bearing assemblies with toothed belt gearing and with integrated bearing elements. Designed as 4-point bearings, they can support equally high loads from all directions and are insensitive to shocks and vibrations. LVE bearing assemblies are sealed on both sides. All Franke bearing assemblies are adjusted to preload.

### Technical data

**Material**  
**Gear**  
**Operating temp.**  
**Peripheral speed.**  
**Lubricant**  
**Relubrication**

Inner / Outer ring:  
Ball race rings:  
Rolling element:  
Cage:  
Sealing:

### LVD (steel)

aluminum (anodized)  
hardened and tempered chrome-silicon steel  
hardened rolling bearing steel  
polyamide or thermoplastic polyurethane  
NBR  
DIN 3967, quality 8e25, straight toothing  
-20 °C to +80 °C, short-term up to +100 °C  
max. 5 m/s, without seal max. 10 m/s  
Shell Gadus S3 V220 C2  
via grease nipples to DIN 3405

### LVL (plastic)

polyoxymethylene (POM)  
non corrosive Steel (1.4310)  
non corrosive Steel  
polyamid (PA12)  
-  
-10 °C to +80 °C  
max. 4 m/s  
Klüber UH1 14-151

# Bearing assemblies as angular contact ball bearing / angular contact roller bearing Typ LVC, LVG

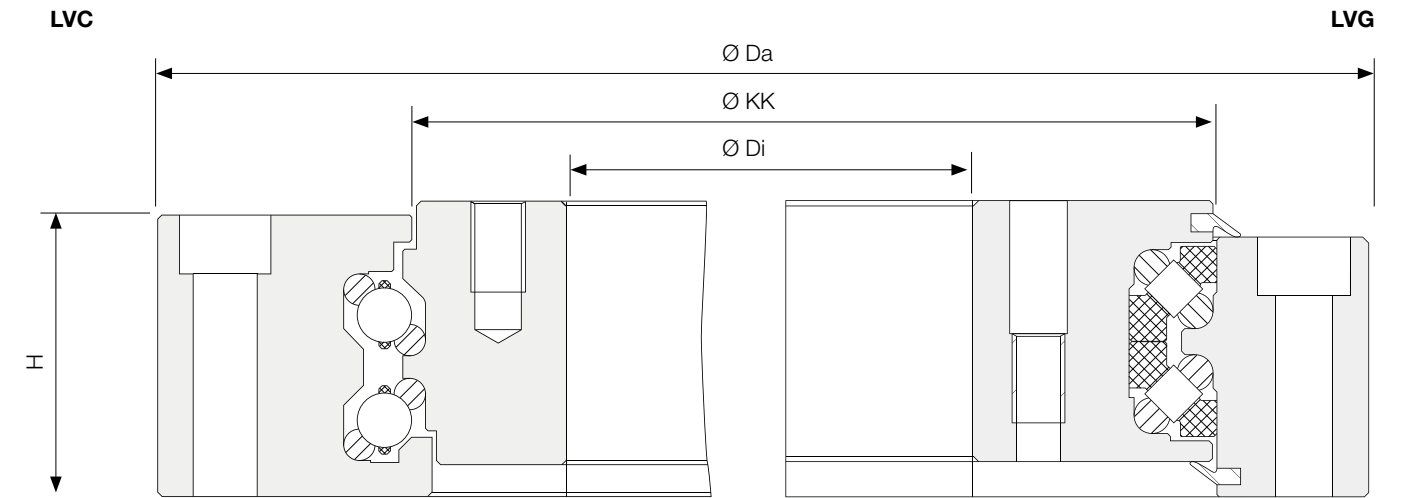
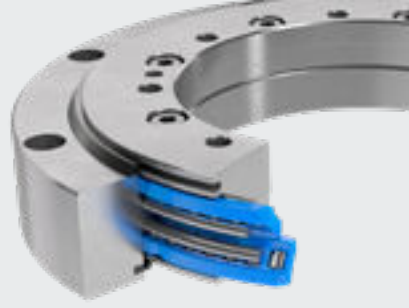

### Dimensions

Type	Mate- rial	Rolling element	Dimensions mm				Load ratings kN				stat. Moment kNm	Weight kg
			Ø KK	Ø Da	Ø Di	H	C <sub>oa</sub>	C <sub>or</sub>	C <sub>a</sub>	C <sub>r</sub>		
LVC	Steel	Balls	100 - 1800	150 - 1930	50 - 1670	34 - 82	53 - 2305	25 - 1085	11 - 85	10 - 73	1 - 976	3.7 - 437.4
LVG	Alum.	Rollers	200 - 400	262 - 475	140 - 323	47 - 57	309 - 827	124 - 331	39 - 90	36 - 83	12.4 - 66.2	4.1 - 12.4

### Characteristics

Franke bearing assemblies type LVC (steel) and type LVG (aluminum) are designed as double row angular contact ball bearings with integrated bearing elements. They are suitable for highest circumferential speeds and loadings and convince by very high dynamics and a very low rotational resistance. Both assemblies are preloaded. They are insensitive to shocks and vibrations. The low rotational resistance and the minimal breakaway torque reduce the required drive power. Due to the low coefficients of friction, both bearing assemblies operate almost maintenance-free and achieve a long service life. Franke LVG are 60% lighter than comparable steel bearings.

### Technical data

**Material**  
Inner / Outer ring:  
Ball race rings:  
Rolling element:  
Cage:  
Sealing:

**Operating temp.**  
**Peripheral speed.**  
**Lubricant**  
**Relubrication**

### LVC (Angular contact ball bearing)

C45N  
hardened and tempered chrome-silicon steel  
hardened rolling bearing steel  
polyamide or thermoplastic polyurethane  
NBR  
DIN 3967, quality 8e25, straight toothing  
-20 °C to +80 °C, short-term up to +100 °C  
max. 5 m/s, without seal max. 10 m/s  
Shell Gadus S3 V220 C2  
via grease nipples to DIN 3405

### LVG (Angular contact roller bearing)

aluminum (anodized)

Rotary table,  
high dynamic  
**Type LTA**



Rotary table,  
high dynamic  
**Typ LTB**

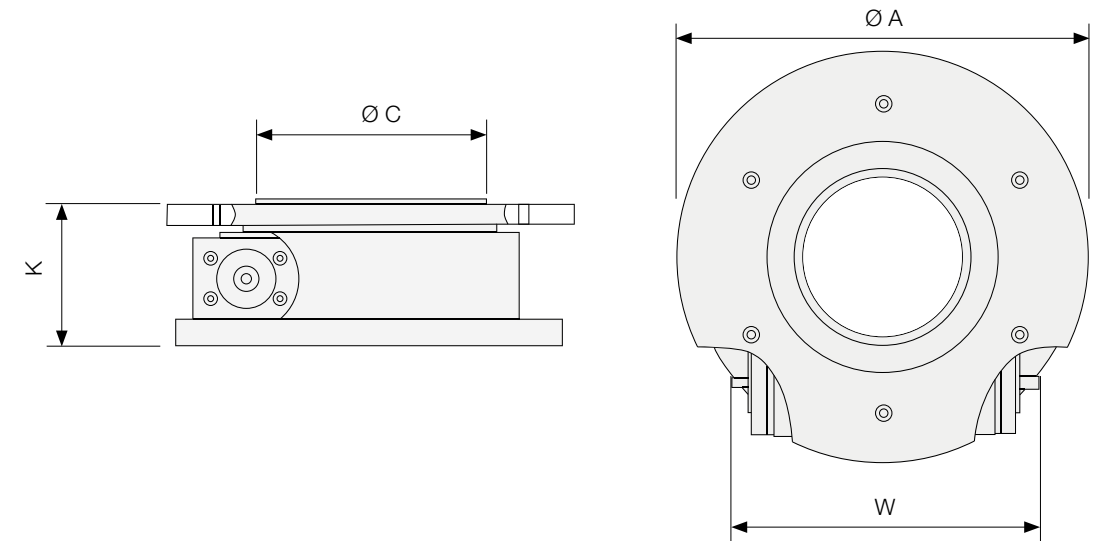
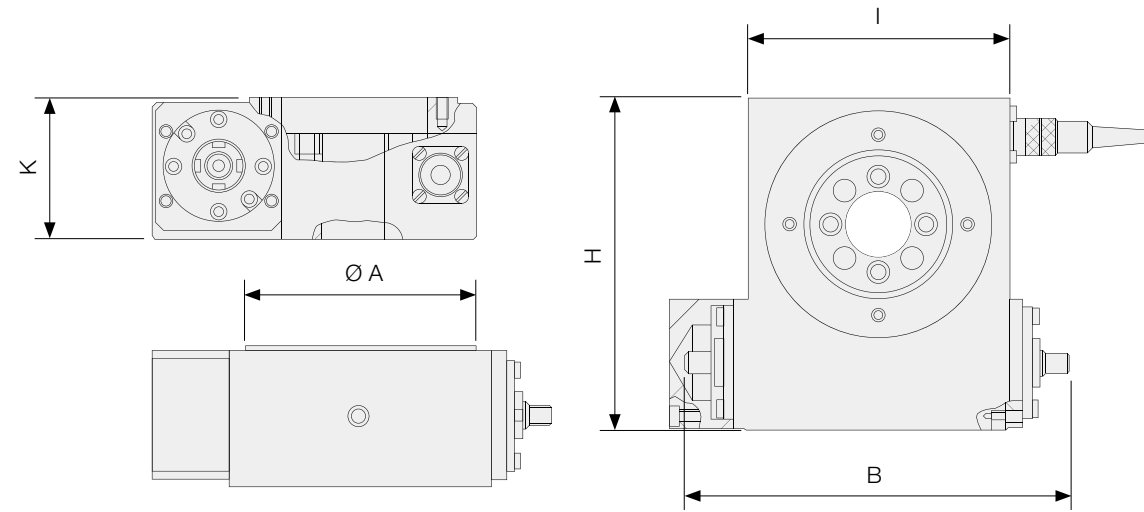

**Dimensions**

Size	Dimensions mm					Weight kg
	Ø A	B	H	I	K	
LTA100	100	183	155	125	65	5.5
LTA200	200	278	255	220	70	10.0

**Performance Overview**

		LTA100	LTA200
Axial / radial accuracy	<b>µm</b>	30	30
Positioning accuracy	<b>sec</b>	160	120
Repeatability	<b>sec</b>	20	14
Load rating C <sub>0</sub>	<b>kN</b>	17.5	43
Load rating C	<b>kN</b>	9	18
Tilting moment C <sub>om</sub>	<b>Nm</b>	289	433
Reduction	<b>i</b>	18	36
Input speed N <sub>1max</sub>	<b>U/min</b>	1800	2200
Output speed N <sub>2max</sub>	<b>U/min</b>	100	61
Input torque M <sub>1max</sub>	<b>Nm</b>	5	5
Output torque M <sub>2max</sub>	<b>Nm</b>	54	108

**Characteristics**

Franke rotary tables type LTA are light, compact, ready to install positioning units. They are highly loadable and have excellent concentricity and axial run-out accuracy. Franke rotary tables type LTA are versatile and are particularly suitable for light machining tasks as well as dynamic handling and assembly applications.

**Technical data**

<b>Material</b>	base plate: Aluminum; Housing: V2A; Ball race rings: hardened and tempered chrome-silicon steel; Rolling element: hardened rolling bearing steel; Worm wheel: Wear-resistant bronze alloy; Worm shaft: CK45N hardened and grinded
<b>Operating temp.</b>	-10 °C to +80 °C
<b>Mounting position</b>	any, preferably horizontal
<b>Lubricant</b>	bearing grease via grease nipples
<b>Options</b>	inductive proximity switch, flange/coupling to mount the motor, motorization

**Dimensions**

Size	Dimensions mm				Weight kg
	Ø A	C	K	W	
LTB125	125	-	75	135	3
LTB175	175	-	82	196	6
LTB265	265	150	90	193	10
LTB400	400	300	100	251	27

**Performance Overview**

		LTB125	LTB175	LTB265	LTB400
Axial / radial accuracy	<b>µm</b>	20	20	20	30
Positioning accuracy	<b>sec</b>	80	80	70	50
Repeatability	<b>sec</b>	16	14	10	8
Load rating C <sub>0</sub>	<b>kN</b>	2	2.6	4.2	14.1
Tilting moment C <sub>om</sub>	<b>Nm</b>	110	140	310	1780
Reduction	<b>i</b>	360	360	360	360
Input speed N <sub>1max</sub>	<b>U/min</b>	2500	2500	2500	2500
Output speed N <sub>2max</sub>	<b>U/min</b>	7	7	7	7
Input torque M <sub>1max</sub>	<b>Nm</b>	0.7	0.9	1.5	2
Output torque M <sub>2max</sub>	<b>Nm</b>	70	75	160	290

**Characteristics**

Franke rotary tables of type LTB are centerless, ready to install positioning units. They are highly loadable, lightweight (aluminum housing) and have an excellent angular accuracy and resolution. Franke rotary tables type LTB can be used in a wide range of applications and are particularly suitable for movement and positioning tasks in the field of measuring, testing and orientation.

**Technical data**

<b>Material</b>	housing: Aluminum ribbed; Ball race rings: hardened and tempered chrome-silicon steel; Rolling element: hardened rolling bearing steel; Worm wheel: Wear-resistant bronze alloy; Worm shaft: CK45N hardened and grinded
<b>Operating temp.</b>	-10 °C bis +80 °C
<b>Mounting position</b>	any, preferably horizontal
<b>Lubricant</b>	bearing grease via grease nipples
<b>Options</b>	inductive proximity switch, flange/coupling to mount the motor, motorization

# Bearing assembly with Torque-Motor Type LTD

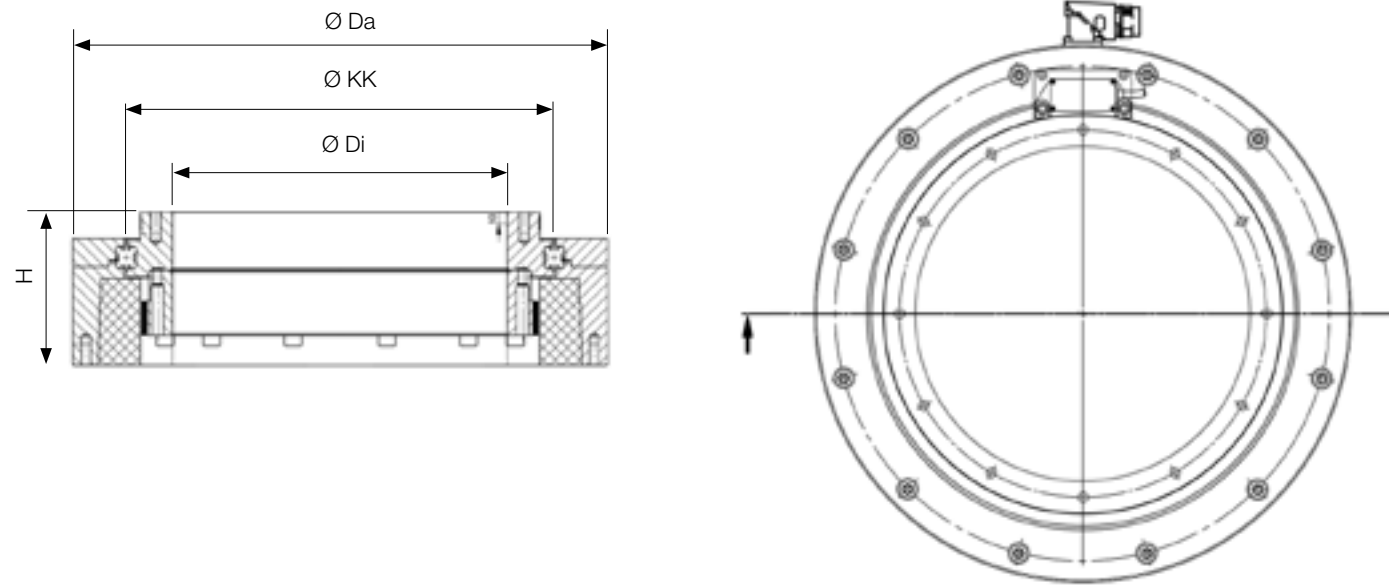

## Dimensions

Type	Dimensions mm				Load ratings kN				Torque Nm		Power A		Speed 1/min.	Weight kg
	Ø KK	Ø Da	Ø Di	H	C <sub>oa</sub>	C <sub>or</sub>	C <sub>a</sub>	C <sub>r</sub>	M <sub>Nenn</sub>	M <sub>Peak</sub>	I <sub>Nenn</sub>	I <sub>Peak</sub>	n <sub>max</sub>	
LTD0100	100	145	50	100	46	22	17	14	4.5	16	1.8	7.0	2140	8
LTD0215	215	265	150	105	128	60	26	22	26.4	105	3.1	12.8	640	21
LTD0320	320	400	250	115	382	180	45	39	77.0	329	4.3	21.6	300	44
LTD0385	385	475	320	115	458	216	48	41	118.0	522	4.3	21.7	193	57

## Characteristics

Bearing assemblies with direct drive are suitable for applications where high performance and low space requirements are important criteria. The integration of the drive into the bearing housing means that wear-prone assemblies for transmitting drive power, such as toothed belts, shafts or chains, can be dispensed with. This reduces the required drive energy and also benefits more accurate positioning.

## Technical data

<b>Material</b>	C45N (optionally aluminum)
<b>Operating temp.</b>	-10 °C to +80 °C
<b>Mounting position</b>	any
<b>Lubricant</b>	bearing grease via grease nipple
<b>Options</b>	absolute measuring system, axial cable outlet, control units incl. cables, water-cooling

Power comparison			LTD0100	LTD0215	LTD0320	LTD0385
<b>Nominal Data (free air convection)</b>						
Nominal Torque	M <sub>NennLk</sub>	Nm	4.5	26.4	77	118
Nominal Current	I <sub>NennLk</sub>	A <sub>eff</sub>	1.8	3.1	4.3	4.3
Nominal Speed	n <sub>NennLk</sub>	U/min	2140	640	299	193
Nominal Power	P <sub>NennLk</sub>	W	1005	1770	2409	2386
Winding Losses	P <sub>VNennLk</sub>	W	54	131	230	309
Total Losses	P <sub>VNennLk</sub>	W	96	179	295	357
Holding Torque	M <sub>HaltLk</sub>	Nm	3.2	18.7	54	83
Holding Current	I <sub>HaltLk</sub>	A <sub>eff</sub>	1.2	2.2	3	3

Peak Data						
Peak Torque	M <sub>Peak</sub>	Nm	16	105	329	522
Peak Current	I <sub>Peak</sub>	A <sub>eff</sub>	7	12.8	21.6	21.7
Speed at Peak Torque	n <sub>Peak</sub>	U/min	1130	320	126	74
Peak Power	M <sub>Peak</sub>	W	1897	3526	4343	4049
Winding Losses	P <sub>Peak</sub>	W	863	2236	5886	7876
Total Losses	P <sub>vPeak</sub>	W	877	2253	5904	7889

Power Data						
Torque Constant	kt	Nm/A <sub>eff</sub>	2.549	8.51	18.037	27.449
		V <sub>eff</sub> /(rad/s)	1.577	5.2	11.094	16.694
BEMF Constant (Phase - Phase)	ke	V <sub>eff</sub> /(U/min)	0.165	0.545	1.162	1.748
Motor Constant	km	Nm/√W	0.459	1.973	4.483	6.25
Idle Speed	n <sub>Leer</sub>	U/min	2390	727	340	226
max. Speed (Fieldweaking)	n <sub>max</sub>	U/min	-	-	-	-
max. Frequency (Idle/Fieldweaking)	f <sub>max</sub>	Hz	398	254	159	124
DC Bus Voltage	UZk	VDC	560	560	560	560
Ø Resistance per Phase (winding only)	R <sub>Ph20</sub>	Ω	4.419	3.457	3.206	4.235
Ø Inductance per Phase (winding only)	L <sub>Ph</sub>	mH	21.727	19.532	21.071	28.049
electr. Time Constant t=L/R	Tel	ms	4.92	5.65	6.57	6.62
Number of Polepairs	n		10	21	28	33
Winding Connection			Star	Star	Star	Star

## Options:

- Housing steel or aluminum
- Housing geometry according to customer requirements
- KKØ: 100 - 1800 mm
- Incremental measuring systems
- Absolute measuring systems
- Cable outlet axial
- Watercooling
- Complete system incl. control and cable

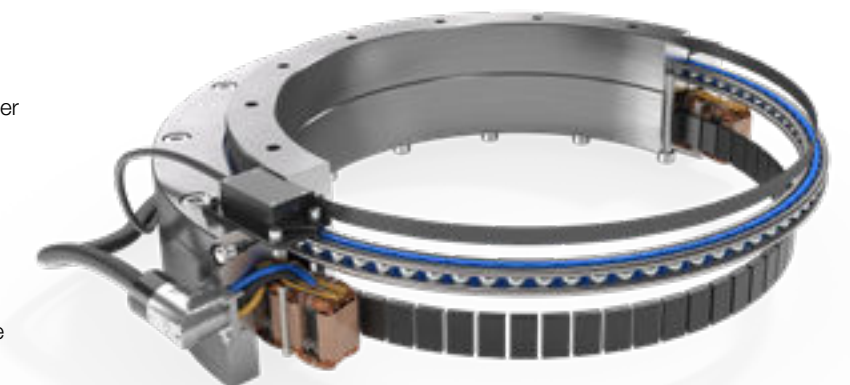

# Uniquely dynamic, uniquely individual: Franke Linear Systems

Franke linear systems transfer the ingenious principle of the wire race bearing to linear movements. Inserted raceways ensure the load capacity on all sides. The rest of the construction can therefore be made of light-weight aluminum. Large guided rollers ensure smooth running - maintenance-free over the entire service life. Thanks to their modular design, Franke linear systems can be individually adapted to requirements.

**Aluminum**  
for cassettes and guide  
rails

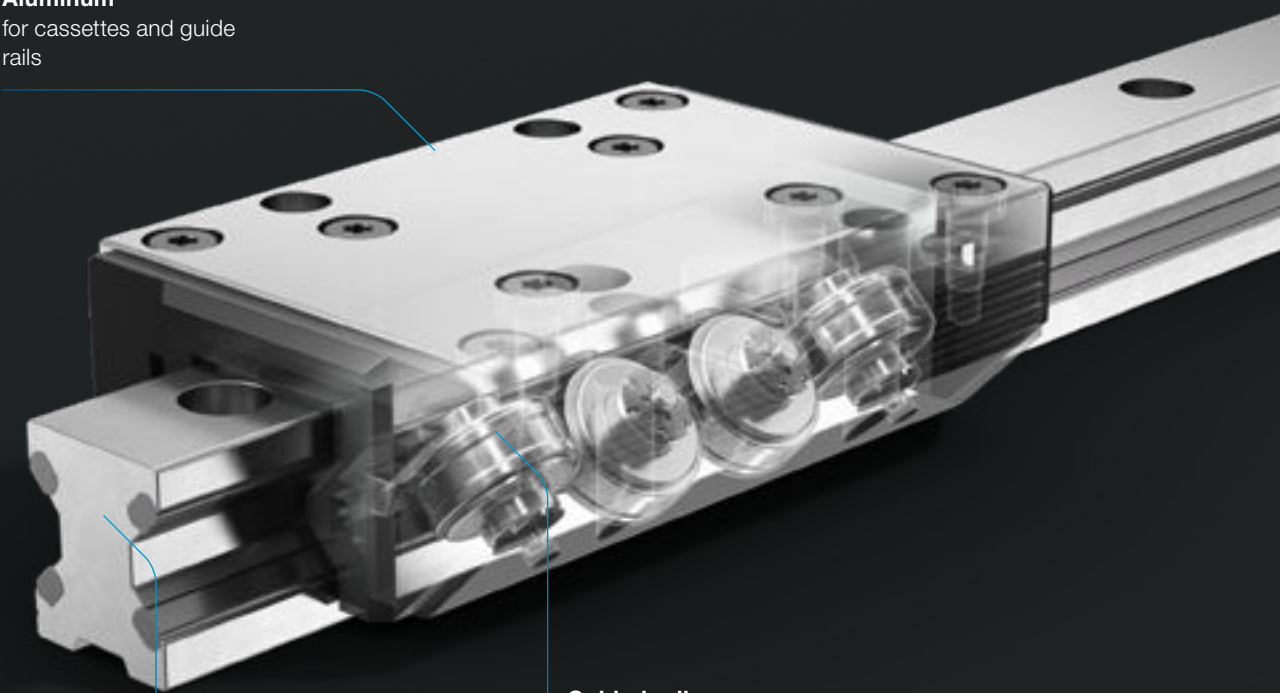

**Guided rollers**  
track rollers with groove  
in O-arrangement

**Profiled raceways**

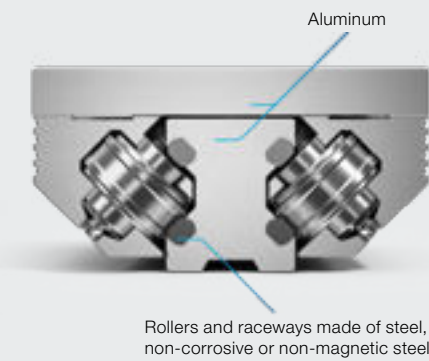

## Designing homogeneously with aluminum

The main components of Franke linear systems - rails and cassettes - are made of aluminium. Franke linear systems are ideally suited for constructions made of aluminum, because the homogeneous materiality excludes temperature-related distortions.

## Highly accurate and durable

Franke's core competence lies in the high-precision manufacture and machining of wire raceways. The pursuit of precision determines every single step of our work. The result is bearing solutions with outstanding accuracy values and an excellent service life.

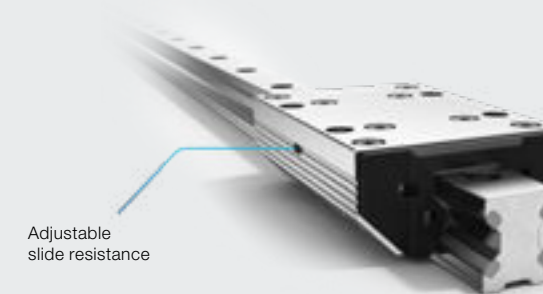

## Always the right sliding resistance

The sliding resistance of Franke linear guides can be adjusted to the application at any time using an adjusting screw. Very fine adjustments are possible. This allows the system to be adapted to the load - in the direction of smooth running or in the direction of stiffness and vibration resistance.

## Maintenance-free – carefree

The needle or ball bearings used in the rollers are lubricated for life. This means that no maintenance is required over the long life of a Franke linear guide. For applications in the food industry we also offer lubricant-free roller bearings.



# The best system for you

Only your application and your construction decide which linear system is the best for you. The Franke modular system makes it possible to put together or design an ideal system for you. X linear system projects in over 45 years prove the efficiency of Franke linear systems.

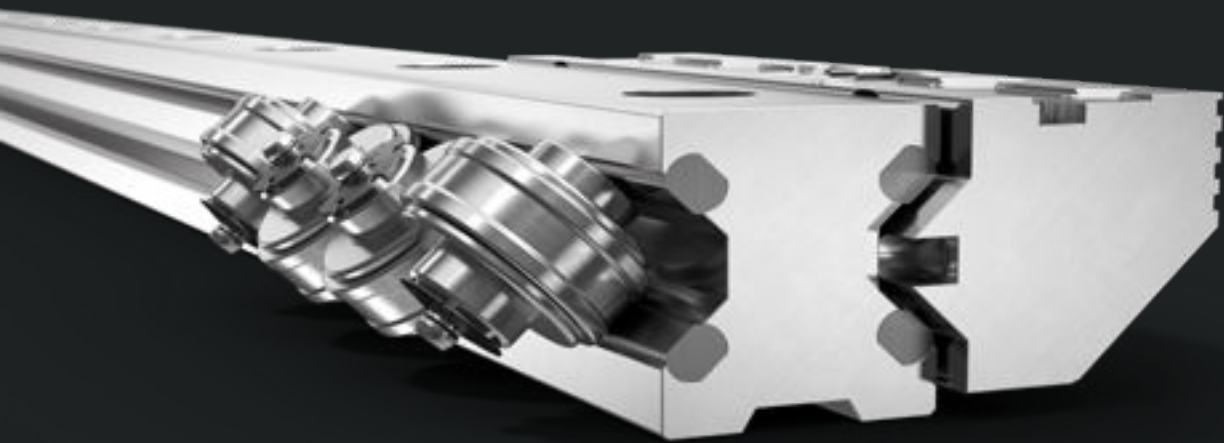

Franke linear systems are the first choice when highest dynamics are required. The large rollers are mounted very smoothly. They run with low friction and precisely guided on the inserted tough and hard steel wires. Because almost exclusively light aluminum is used for the entire construction, the moving mass is low. The result: Highest dynamics and energy efficiency.

# Your solution - delivered quickly

You will probably already find the right linear system for your application in our varied standard program. Many product types are available from stock at short notice. Further requirements can be met individually - just ask us.

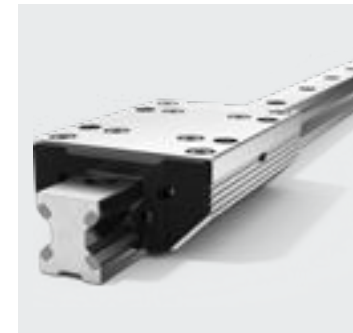

## Double rail & cassette

The double rail version consists of only two components: the profile rail and the cassette running on it. Profile and cassette shapes can be adapted individually. It is possible to stabilise the base by means of a wider profile.



## Pair of single rails & pair of roller shoes

When designed as a pair of individual rails, the guide width can be freely adjusted over the distance between the two rails. Franke supplies rails and roller shoes. The roller shoes are screwed directly to the continuing construction, therefore a cassette plate is not necessary. The shape of the rail profiles and the roller shoes can be adapted individually.



## Linear tables and linear modules with drive

Franke linear tables and modules are linear systems with integrated drive mechanics. You can choose between spindle or toothed belt drive. In terms of shape, stroke length and design, we are gladly prepared to design linear systems according to your individual requirements.

# Linear Guides with Double rail and Cassette Typ FD-K

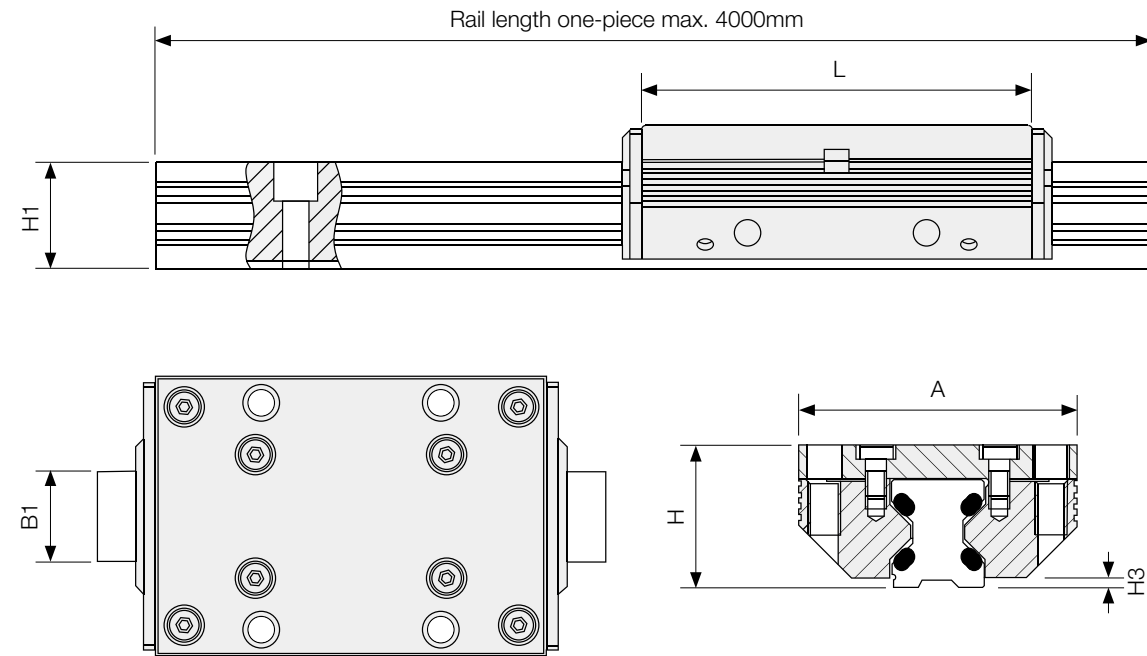
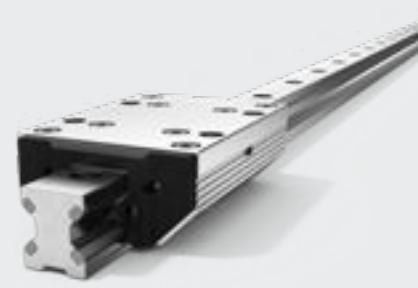

## Dimensions

Size	Dimensions mm						Available series
	A	B1	H	H1	H3	L	
12	37	12.0	19	14.7	1.4	64	FDA, FDB, FDC, - , FDE, FDG, -
15	47	15.5	24	18.7	2.0	78	FDA, FDB, FDC, - , FDE, FDG, -
20	63	21.0	30	22.6	2.0	92	FDA, FDB, FDC, - , FDE, FDG, -
25	70	23.0	36	27.0	2.5	98	FDA, FDB, FDC, FDD, FDE, FDG, FDH
35	100	32.0	48	37.0	3.5	135	FDA, FDB, FDC, - , FDE, FDG, FDH
45	120	45.0	60	46.0	4.0	165	FDA, FDB, FDC, - , FDE, FDG, FDH

## Characteristics

Franke linear systems are the best solution when it comes to speed and lightweight construction. Due to their design principle, Franke linear systems are highly dynamic, quiet and maintenance-free. Thanks to a modular design, Franke linear systems can be individually adapted to customer requirements. By using different rail profiles and roller shoes, special cassettes, variable track widths or an integrated direct drive, you always get a solution optimized for your application. The sliding resistance can be individually adjusted. The guide rails are available in one piece up to 4000 mm and can be coupled endlessly.

## Technical data

<b>Material</b>	cassette plate, roller shoes and rail body: aluminum; rollers and running bars: steel, non-corrosive or non-magnetic steel
<b>Operating temp.</b>	-10 °C to +80 °C
<b>Vmax</b>	10 m/s
<b>Mounting position</b>	any
<b>Lubricant</b>	lifetime-lubricated, maintenance-free

# Linear Guides with single rails and pair of roller shoes Type FD-R

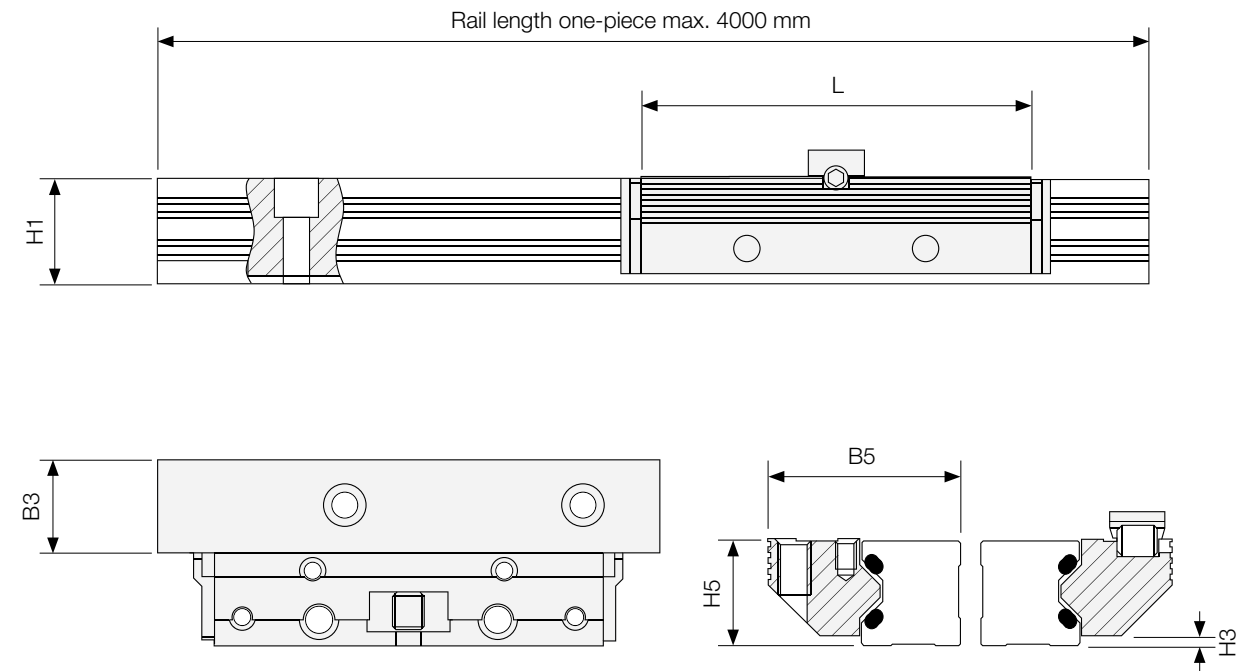

## Dimensions

Size	Dimensions mm						Available series
	B3	B5	H1	H3	H5	L	
12	12.00	24.4	14.7	1.4	15.0	64	FDA, FDB, FDC, - , FDE, FDG, -
15	15.25	30.9	18.7	2.0	19.0	78	FDA, FDB, FDC, - , FDE, FDG, -
20	20.00	40.9	22.6	2.0	23.0	92	FDA, FDB, FDC, - , FDE, FDG, -
25	25.00	48.4	27.0	2.5	27.5	98	FDA, FDB, FDC, FDD, FDE, FDG, FDH
35	35.00	68.9	37.0	3.5	37.5	135	FDA, FDB, FDC, - , FDE, FDG, FDH
45	45.00	82.4	46.0	4.0	46.5	165	FDA, FDB, FDC, - , FDE, FDG, FDH

## Characteristics

Franke linear systems are the best solution when it comes to speed and lightweight construction. Due to their design principle, Franke linear systems are highly dynamic, quiet and maintenance-free. Thanks to a modular design, Franke linear systems can be individually adapted to customer requirements. By using different rail profiles and roller shoes, special cassettes, variable track widths or an integrated direct drive, you always get a solution optimized for your application. The sliding resistance can be individually adjusted. The guide rails are available in one piece up to 4000 mm and can be coupled endlessly.

## Technical data

<b>Material</b>	roller shoes and rail body: aluminum; rollers and running bars: steel, non-corrosive or non-magnetic steel
<b>Operating temp.</b>	-10 °C to +80 °C
<b>Vmax</b>	10 m/s
<b>Mounting position</b>	any
<b>Lubricant</b>	lifetime-lubricated, maintenance-free



# Linear Guides Type FD

## Available types

Type	Characteristics	Application possibilities
FDA	<ul style="list-style-type: none"> <li>aluminum roller guides in <b>standard</b> design</li> <li>inlaid steel raceways</li> <li>rollers with needle bearings for easy and quiet running</li> </ul>	Suitable for linear motion applications in virtually all industries. Sealed track rollers for maintenance-free operation over the entire service life. Smooth, clean running.
FDB	<ul style="list-style-type: none"> <li>aluminum roller guides in <b>LowCost</b> design</li> <li>inlaid steel raceways</li> <li>ball bearing mounted rollers</li> </ul>	Suitable for linear motion applications in virtually all industries. Particularly suitable for cost-sensitive applications with reduced load and noise requirements.
FDC	<ul style="list-style-type: none"> <li>aluminum roller guides in <b>NIRO</b> design</li> <li>inserted raceways made of corrosion-free steel</li> <li>stainless steel track rollers with needle bearings for smooth and quiet running</li> </ul>	Suitable for linear motion applications in virtually all industries. Insensitive to environmental influences as well as moisture or cleaning agents.
FDD	<ul style="list-style-type: none"> <li>aluminum roller guides in <b>amagnetic</b> design</li> <li>inlaid raceways made of amagnetic steel</li> <li>rollers with needle bearings for easy and quiet running</li> </ul>	Suitable for linear motion applications in virtually all industries. Amagnetic raceways without influence on prevailing magnetic fields (e.g. in medical technology or electronics manufacturing).
FDE	<ul style="list-style-type: none"> <li>aluminum roller guides in <b>lubricant-free</b> design</li> <li>inlaid raceways made of steel</li> <li>lubricant-free rollers for easy and quiet running</li> </ul>	Suitable for linear motion tasks in almost all industries. Special track rollers without lubricants. Suitable for use in vacuum or clean rooms.
FDG	<ul style="list-style-type: none"> <li>aluminum roller guides in <b>NIRO-LowCost</b> Design</li> <li>inserted raceways made of corrosion-free steel</li> <li>ball-bearing track rollers made of corrosion-free steel</li> </ul>	Suitable for linear motion applications in virtually all industries. Especially suitable for cost-sensitive applications in harsh environments or when using cleaning agents.
FDH	<ul style="list-style-type: none"> <li>aluminum roller guides in <b>highly dynamic</b> design</li> <li>inserted raceways made of steel</li> <li>track rollers with sealed angular contact ball bearings</li> </ul>	Suitable for linear motion applications in virtually all industries. Track rollers with angular contact ball bearings for maximum acceleration and speed values, for example when using linear motors as a drive source.
FDI	<ul style="list-style-type: none"> <li>aluminum roller guides in <b>vacuum-compatible</b> design</li> <li>inserted raceways made of corrosion-free steel</li> <li>rollers in full-needle, corrosion-free design</li> </ul>	Suitable for linear motion tasks in almost all industries. Full complement needle rollers without cage to avoid outgassing.

# Linear Tables

## mit spindle drive and metal cover

### Type FTB

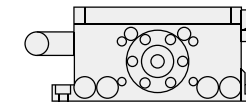
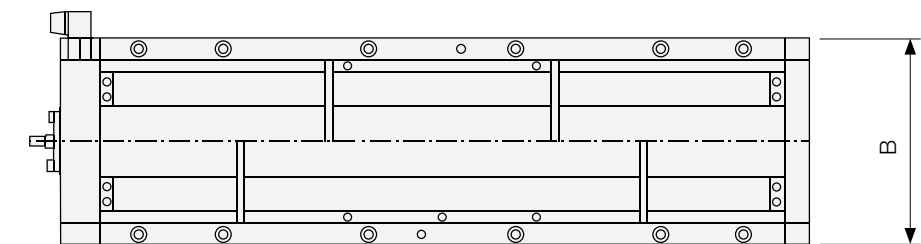
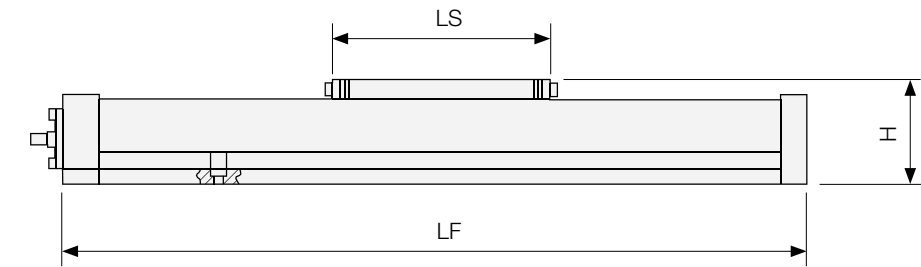

#### Dimensions

Size	Dimensions mm				Load rating N	Moments Nm		Weight kg	
	Stroke	B	H	LF		LS	C		M <sub>cx</sub>
FTB06A	100-1500	155	70	315-1715	165	15000	670	220	6.4 - 21.8
FTB06B	100-1500	155	70	430-1830	280	30000	1380	1930	7.5 - 22.9

#### Characteristics

Franke FTB linear tables are lightweight, compact, ready-to-install positioning units. They are highly resilient and have excellent positioning accuracy. Franke linear tables type FTB are equipped with an integrated aluminum roller guide, a preloaded ball screw and a metal cover.

#### Technical data

<b>Material</b>	base body: AlZnMgCu05, integrated aluminum roller guide: AlZnMgCu05, raceways: steel, rollers: steel, cover: stainless steel sheet
<b>Operating temp.</b>	-10 °C to +80 °C
<b>V<sub>max</sub></b>	15 m/min
<b>Mounting position</b>	any
<b>Lubricant</b>	lifetime-lubricated, maintenance-free

# Linear Modules with external guides Type FTC



design with  
toothed belt drive

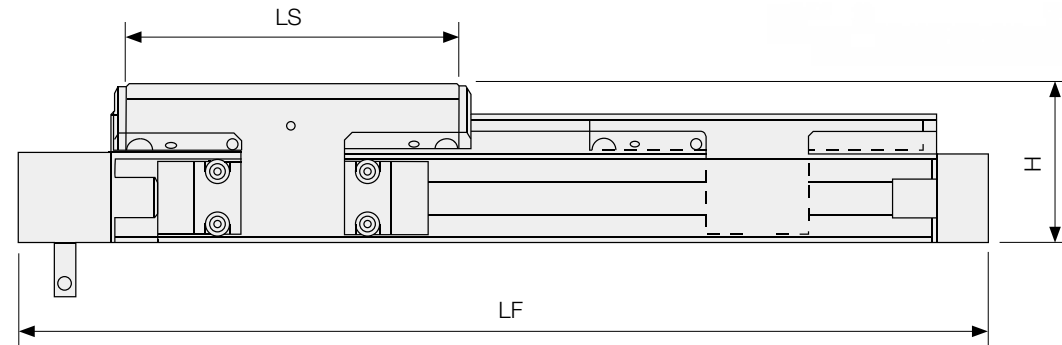

design with  
spindle drive

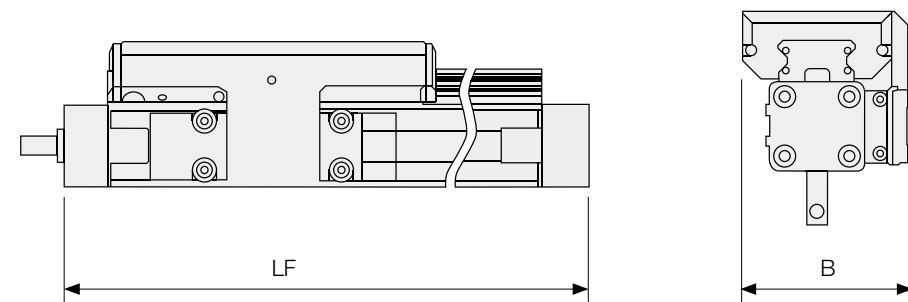

## Dimensions

Size	Dimension mm					Load rating N	Moments Nm		Weight kg
	Hub	B	H	LF	LS		$M_{cx}$	$M_{cy}/M_{cz}$	
<b>Toothed belt drive</b>									
FTC15	00-3400	72,5	73.5	360-3660	54	4200	81	190	3.0-13.9
FTC20	100-3400	91.0	88.0	411-3711	197	5400	133	338	5.5-28.6
FTC25	100-3200	117.0	118.5	524-3624	276	13500	483	922	12.4-43.4
<b>Spindle drive</b>									
FTC15	100-1100	72.5	73.5	300-1300	154	4200	81	190	3.0-7.0
FTC20	100-2000	91.0	88.0	350-2250	197	5400	133	338	5.6-18.9
FTC25	100-3200	117.0	118.5	500-3600	276	13500	483	922	12.6-53.2

## Characteristics

Franke liner modules type FTC are light, compact, ready-to-install positioning units. They are preferably suitable for fast, dynamic motion tasks. The external guide system is moved by an internal spindle or toothed belt drive. Franke FTC linear modules are very versatile. The guide cassette can be designed to meet customer specific requirements.

## Technical data

<b>Material</b>	housing: AlZnMgCu05, attached aluminium roller guide: AlZnMgCu05, raceways / rollers: steel, optional steel spindle/plastic toothed belt
<b>Operating temp.</b>	-10° C to +80° C
<b>Vmax</b>	5 m/s
<b>Mounting position</b>	any
<b>Lubricant</b>	lifetime-lubricated, maintenance-free

# Linear Modules with integrated guides Type FTD

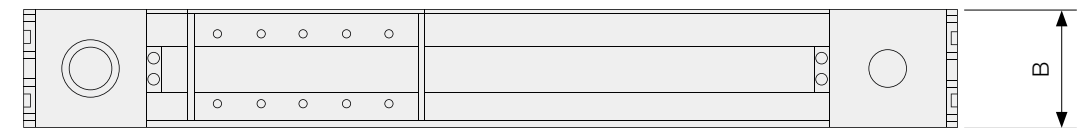
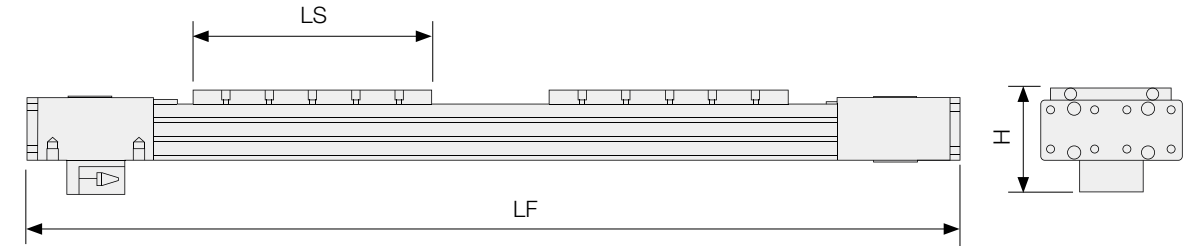
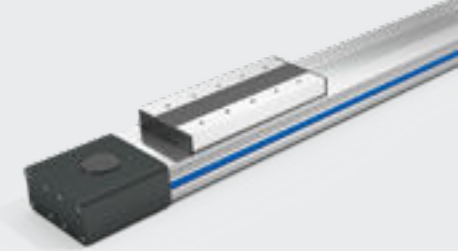

## Dimensions

Size	Dimensions mm					Load rating N	Moments Nm		Weight kg
	Hub	B	H	LF	LS		$M_{cx}$	$M_{cy}/M_{cz}$	
FTD15	100-7000	93	52.5	536-7436	178	4200	45	274	5.2-34.9
FTD20	100-7000	116	66.5	624-7524	218	5400	76	460	10.3-56.5
FTD35	100-7000	175	92.5	794-7694	263	12500	294	1233	28.8-133.7

## Charakteristik

Franke liner modules type FTD are light, compact, ready-to-install positioning units. They have an extremely space-saving design and combine the guide system and toothed belt drive protected within the module housing.

Franke linear modules of type FTD are versatile and bridge even large lifting ranges of up to 7 meters in length.

## Technical data

<b>Material</b>	housing: AlZnMgCu05, integrated aluminum roller guide: AlZnMgCu05, raceways / rollers: steel, plastic toothed belt
<b>Operating temp.</b>	-10° C to +80° C
<b>Vmax</b>	10 m/s
<b>Mounting position</b>	any
<b>Lubricant</b>	lifetime-lubricated, maintenance-free

[www.franke-gmbh.com](http://www.franke-gmbh.com)



Franke GmbH  
Obere Bahnstraße 64  
73431 Aalen  
Tel. +49 7361 920-0  
[info@franke-gmbh.de](mailto:info@franke-gmbh.de)

